



**5104-ARUNAI ENGINEERING COLLEGE**

VELU NAGAR, TIRUVANNAMALAI – 606 603.



**DEPARTMENT OF MECHANICAL ENGINEERING**

**GE 8261 – ENGINEERING PRACTICES  
LABORATORY**

**LABORATORY MANUAL**

## **MECHANICAL ENGINEERING PRACTICE**

### **Welding:**

- (a) Preparation of arc welding of butt joints, lap joints and tee joints.
- (b) Gas welding practice

### **Basic Machining:**

- (a) Simple Turning and Taper turning
- (b) Drilling Practice

### **Sheet Metal Work:**

- (a) Forming & Bending:
- (b) Model making – Trays, funnels, etc.
- (c) Different type of joints.

### **Machine assembly practice:**

- (a) Study of centrifugal pump
- (b) Study of air conditioner

### **Demonstration on:**

- (a) Smithy operations, upsetting, swaging, setting down and bending. Example –  
Exercise – Production of hexagonal headed bolt.17
- (b) Foundry operations like mould preparation for gear and step cone pulley.
- (c) Fitting – Exercises – Preparation of square fitting and vee – fitting models.

### **Equipment Required**

1. Arc welding transformer with cables and holders 5 Nos.
2. Welding booth with exhaust facility 5 Nos.
3. Welding accessories like welding shield, chipping hammer,  
Wire brush, etc. 5 Sets.
4. Oxygen and acetylene gas cylinders, blow pipe and other  
Welding outfit. 2 Nos.
5. Centre lathe 2 Nos.
6. Hearth furnace, anvil and smithy tools 2 Sets.
7. Moulding table, foundry tools 2 Sets.
8. Power Tool: Angle Grinder 2 Nos
9. Study-purpose items: centrifugal pump, air-conditioner One each.

## **LIST OF EXPERIMENTS**

<b>CONTENT</b>	<b>Page No.</b>
<b>WELDING</b>	4
1. Butt Joint	18
2. Lap Joint	21
3. T-Joint	24
<b>LATHE</b>	26
1. Turning, Facing and Chamfering	38
2. Taper turning	41
3. Drilling and Tapping	44
<b>SHEET METAL</b>	55
1. Cone Making	63
2. Tray Making	66
<b>TOPIC BEYOND SYLLABUS</b>	71

# WELDING

## **WELDING**

Welding is a fabrication process that joins materials, usually metals or thermoplastics, by causing coalescence. This is often done by melting the work pieces and adding a filler material to form a pool of molten material (the weld puddle) that cools to become a strong joint, with pressure sometimes used in conjunction with heat, or by itself, to produce the weld. This is in contrast with soldering and brazing, which involve melting a lower-melting-point material between the work pieces to form a bond between them, without melting the work pieces.

Many different energy sources can be used for welding, including a gas flame, an electric arc, a laser, an electron beam, friction, and ultrasound. While often an industrial process, welding can be done in many different environments, including open air, underwater and in space. Regardless of location, however, welding remains dangerous, and precautions must be taken to avoid burns, electric shock, eye damage, poisonous fumes, and overexposure to ultraviolet light.

### **TYPES OF WELDING**

#### **Arc Welding**

Arc welding is a process utilizing the concentrated heat of an electric arc to join metal by fusion of the parent metal and the addition of metal to joint usually provided by a consumable electrode. Either direct or alternating current may be used for the arc, depending upon the material to be welded and the electrode used.

#### **Gas Welding**

It is a metal joining process in which the ends of pieces to be joined are heated at their interface by producing coalescence with one or more gas flames (such as oxygen and acetylene), with or without the use of a filler metal.

#### **Welding Safety**

Welding hazards pose an unusual combination of safety and health risks. By its nature, welding produces fumes and noise, gives off radiation, involves electricity or gases, and has the potential for burns, shock, fire, and explosions.

Some hazards are common to both electric arc and oxygen-fuel gas welding. If you work with or near a welding operation, the following general precautions should help you to work more safely.

- Weld only in designated areas.
  - Only operate welding equipment you have been trained to use.
  - Know what the substance is that's being welded and any coating on it.
  - Wear protective clothing to cover all exposed areas of the body for protection sparks, hot spatter, and radiation.
  - Protective clothing should be dry and free of holes, grease, oil, and other substances which may burn.
  - Wear flameproof gauntlet gloves, a leather or asbestos apron, and high-top shoes to provide good protection against sparks and spatter.
  - Wear specifically designed, leak-proof helmets equipped with filter plates to protect against ultraviolet, infrared, and visible radiation.
  - Never look at a flash, even for an instant.
- 
- Keep your head away from the plume by staying back and to the side of the work.
  - Use your helmet and head position to minimize fume inhalation in your breathing zone.
  - Make sure there is good local exhaust ventilation to keep the air in your breathing zone clear.
  - Don't weld in a confined space without adequate ventilation and a NIOSH-approved respirator.
  - Don't weld in wet areas, wear wet or damp clothing or weld with wet hands.
  - Don't weld on containers which have held combustible materials or on drums, barrels or tanks until proper safety precautions have been taken to prevent explosions.
  - If others are working in the area be sure they are warned and protected against arcs, fumes, sparks, and other welding hazards.
  - Don't coil the electrode cable around your body.
  - Ground both the frame of the welding equipment and metal being welded.
  - Check for leaks in gas hoses using an inert gas.
  - Check area around you before welding to be sure no flammable material or degreasing solvents are in the welding area.
  - Keep a fire watch in the area during and after welding to be sure there are no smoldering materials, hot slag or live sparks which could start a fire.
  - Locate the nearest fire extinguisher before welding.
  - Deposit all scraps and electrode butts in proper waste container to avoid fire and toxic fumes.

## Types of arc welding

Different types of arc welding are.

1. Carbon arc welding
2. Metal arc welding
3. Metal inert gas welding
4. Submerged arc welding
5. Plasma arc welding etc.

## Electric Arc Welding,

Electric arc welding is the most widely used of the various arc welding processes. Welding is performed with the heat of an electric arc that is maintained between the end of a coated metal electrode and the work piece (See Figure 1). The heat produced by the arc melts the base metal, the electrode core rod, and the coating. As the molten metal droplets are transferred across the arc and into the molten weld puddle, they are shielded from the atmosphere by the gases produced from the decomposition of the flux coating. The molten slag floats to the top of the weld puddle where it protects the weld metal from the atmosphere during solidification. Other functions of the coating are to provide arc stability and control bead shape. More information on coating functions will be covered in subsequent lessons.

**Welding Power Sources:** Shielded metal arc welding may utilize either alternating current (AC) or direct current (DC), but in either case, the power source selected must be of the constant current type. This type of power source will deliver relatively constant amperage or welding current regardless of arc length variations by the operator the amperage determines the amount of heat at the arc and since it will remain relatively constant, the weld beads produced will be uniform in size and shape.

Whether to use an AC, DC, or AC/DC power source depends on the type of welding to be done and the electrodes used. The following factors should be considered: 1. **Electrode Selection** - Using a DC power source allows the use of a greater range of electrode types. While most of the electrodes are designed to be used on AC or DC, some will work properly only on DC.

2. **Metal Thickness** - DC power sources may be used for welding both heavy sections and light gauge work. Sheet metal is more easily welded with DC because it is easier to strike and maintain the DC arc at low currents.

**3. Distance from Work** - If the distance from the work to the power source is great, AC is the best choice since the voltage drop through the cables is lower than with DC. Even though welding cables are made of copper or aluminum (both good conductors), the resistance in the cables becomes greater as the cable length increases. In other words, a voltage reading taken between the electrode and the work will be somewhat lower than a reading taken at the output terminals of the power source. This is known as voltage drop.

**4. Welding Position** - Because DC may be operated at lower welding currents, it is more suitable for overhead and vertical welding than AC. AC can successfully be used for out-of-position work if proper electrodes are selected.

**5. Arc Blow** - When welding with DC, magnetic fields are set up throughout the weldment. In weldments that have varying thickness and protrusions, this magnetic field can affect the arc by making it stray or fluctuate in direction. This condition is especially troublesome when welding in corners. AC seldom causes this problem because of the rapidly reversing magnetic field produced.

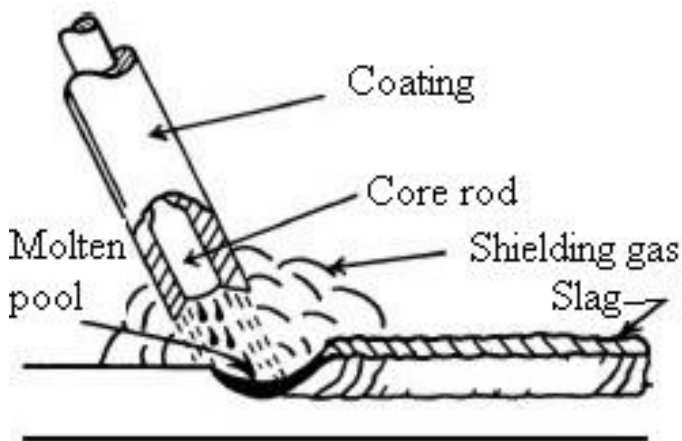

### Oxy-Acetylene gas Welding

Oxyacetylene welding, commonly referred to as gas welding, is a process which relies on combustion of oxygen and acetylene. When mixed together in correct proportions within a hand-held torch or blowpipe, a relatively hot flame is produced with a temperature of about 3,200°C. The chemical action of the oxyacetylene flame can be adjusted by changing the ratio of the volume of oxygen to acetylene.

Three distinct flame settings are used, neutral, oxidising and carburizing. Welding is generally carried out using the neutral flame setting which has equal quantities of oxygen and acetylene. The oxidising flame is obtained by increasing just the oxygen flow rate while the carburising flame is achieved by increasing acetylene flow in relation to oxygen flow. Because steel melts at a temperature above



1,500°C, the mixture of oxygen and acetylene is used as it is the only gas combination with enough heat to weld steel. However, other gases such as propane, hydrogen and coal gas can be used for joining lower melting point non-ferrous metals, and for brazing and silver soldering.

## Equipment

Oxyacetylene equipment is portable and easy to use. It comprises oxygen and acetylene gases stored under pressure in steel cylinders. The cylinders are fitted with regulators and flexible hoses which lead to the blowpipe. Specially designed safety devices such as flame traps are fitted between the hoses and the cylinder regulators. The flame trap prevents flames generated by a 'flashback' from reaching the cylinders; principal causes of flashbacks are the failure to purge the hoses and overheating of the blowpipe nozzle.

When welding, the operator must wear protective clothing and tinted coloured goggles. As the flame is less intense than an arc and very little UV is emitted, general-purpose tinted goggles provide sufficient protection

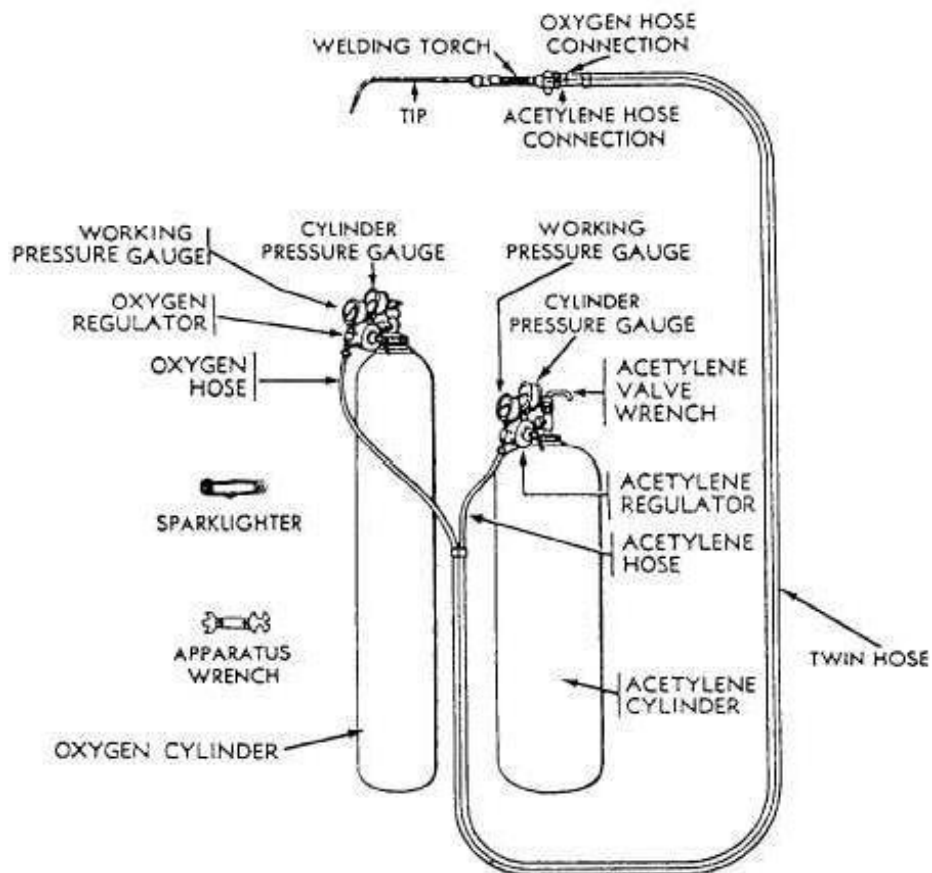

## **Neutral Flame**

As the supply of oxygen to the blowpipe is further increased; the flame contracts and the white cone become clearly defined, assuming a definite rounded shape. At this stage approximately equal quantities of acetylene and oxygen are being used and the combustion is complete, all the carbon supplied by the acetylene is being consumed and the maximum heat given out. The flame is now neutral, and this type of flame is the one most extensively used by the welder, who should make himself thoroughly familiar with its appearance and characteristics.

## **Carburising Flame**

This is a flame in which an excess of acetylene is burning, i.e. combustion is incomplete and unconsumed carbon is present. When lighting the blowpipe the acetylene is turned on first and ignited, giving a very smoky yellow flame of abnormal size, showing two cones of flame in addition to an outer envelope; this is an exaggerated form of the carburising flame, but gives out comparatively little heat and is of little use for welding.

## **Oxidising Flame**

A further increase in the oxygen supply will produce an oxidising flame in which there is more oxygen than is required for complete combustion. The inner cone will become shorter and sharper, the flame will turn a deeper purple colour and emit a characteristic slight "hiss", while the molten metal will be less fluid and tranquil during welding and excessive sparking will occur. An oxidising flame is only used for special applications, and should never be used for welding

## **Welding Tools and Safety Equipments**

### **Goggles**

**Goggles** are forms of protective eyewear that usually enclose or protect the eye area in order to prevent particulates, infectious fluids, or chemicals from striking.

### **Face Shield**

Face shield is used to protect the eyes of the welder from the little sparks produced during welding. It is normally held in hand.

### **Hand Gloves**

Hand gloves are used to protect the hands from electrical shock, arc radiation and hot spatters.

## **Tongs**

Tongs are used to handle the hot metal – welding job while cleaning. They are also used to hold the metal for hammering.

## **Chipping Hammer**

Chipping hammer is a chisel shaped tool and is used to remove the slag from the weld bead.

## **Wire brush**

A wire brush is made up of stiff steel wire embedded in a wooden piece. It removes small particles of slag from the weld bead after the chipping hammer has done its job.

## **Welding Helmet**

Welding helmets are headgear used when performing certain types of welding to protect the eyes , face and neck from flash burn, ultraviolet light, sparks and heat. Welding helmets can also prevent retina burns, which can lead to a loss of vision.

## **Ground Clamp**

It is connected to the end of the ground cable. It is normally clamped to the welding table or the job itself to complete the electric circuit.

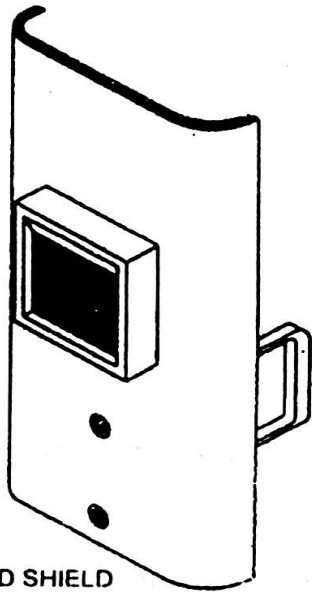

HAND SHIELD

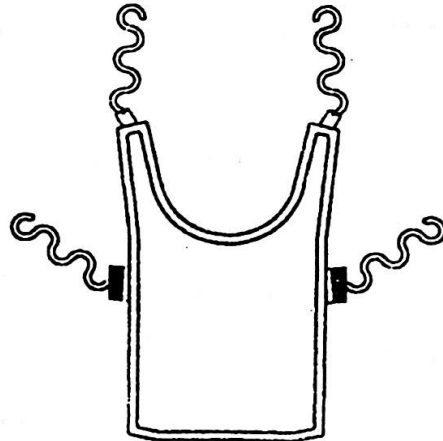

WELDING APRON



HAND GLOVES

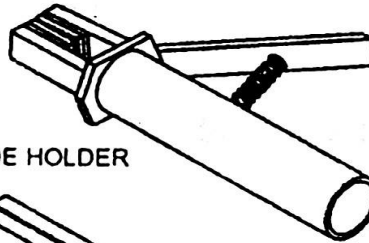

ELECTRODE HOLDER

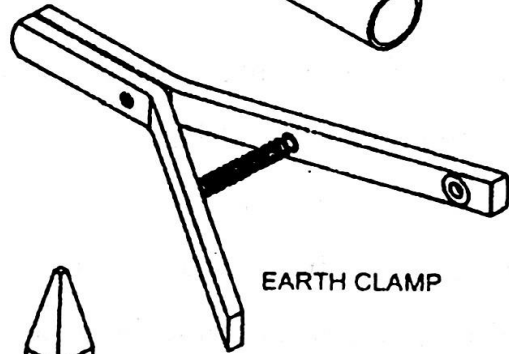

EARTH CLAMP

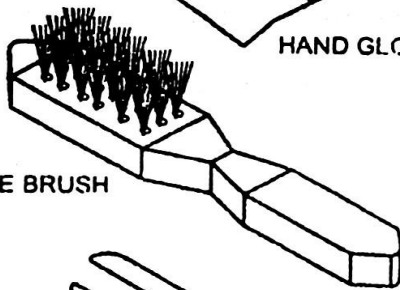

WIRE BRUSH

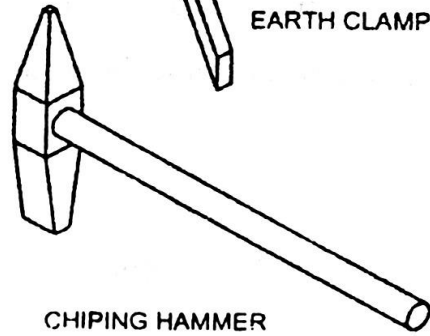

CHIPING HAMMER

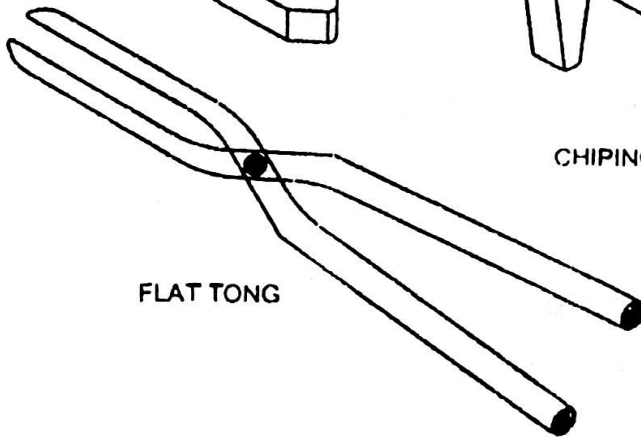

FLAT TONG

## **Advantages of Arc Welding**

1. A big range of metals and their alloys can be welded
2. Welding equipment is portable and the cost is fairly low
3. Flux shielded manual metal arc welding is the simplest of all the arc welding processes.
4. The applications of the arc welding are innumerable, because of the availability of wide variety of electrodes.
5. Welding can be carried out in any position with highest weld quality.

## **Disadvantages of arc welding**

1. Because of the limited length of each electrode and brittle flux coating on it, mechanization is difficult.
2. In welding long joints, as one electrode finishes, the weld is to be progressed with the next electrode. A defect may occur at the place where welding is restarted with the new electrode.

## **Applications**

1. In reservoir tank, boiler and pressure vessel fabrications
2. Ship building
3. Pipes and pen stock joining
4. Building and bridge construction
5. Automotive and air craft industry

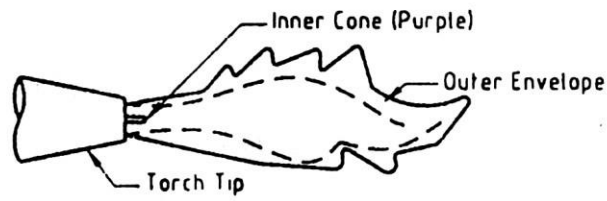
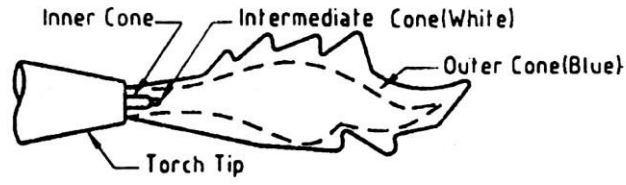
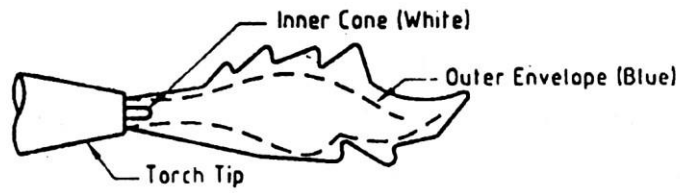

**TYPES OF OXY-ACETYLENE FLAME**

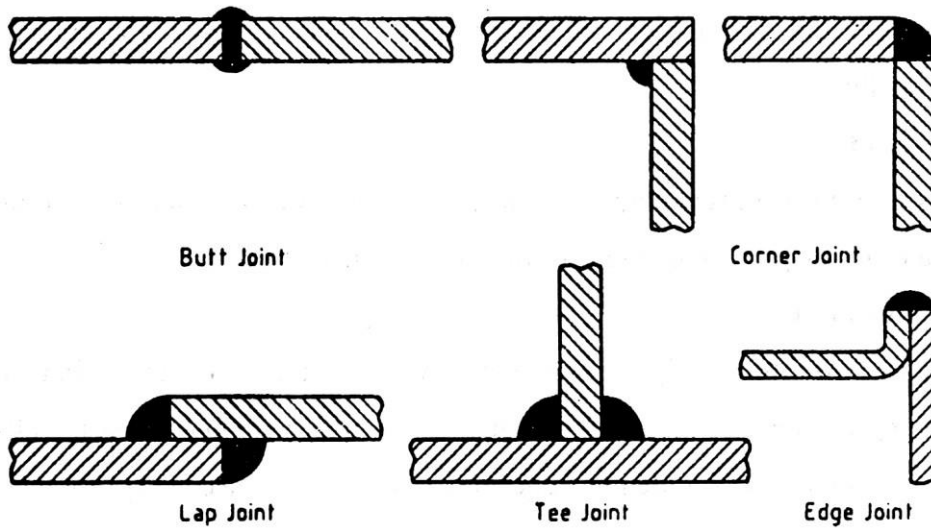

**BASIC TYPES OF WELDED JOINTS**

## **Types of Joints**

The joints used in welding are

1. Butt joint
2. Lap joint
3. Edge joint
4. T – joint
5. Corner joint

### **1. Butt joint**

It is used to join the ends or edges of plates lying in the same plane. Plates having thickness less than 5mm do not require edge preparation but plates having thickness more than 5mm require edge preparation on both sides.

### **2. Lap joint**

It is used to join two overlapping pieces so that the edges of each piece are welded to the surface of the other. It is used on plates less than 3mm thickness. Common types are single lap and double lap joint. Edge preparation is not required for these joints.

### **3. Edge joint**

It is used to weld two parallel plates. This is economical for joining thin plates up to 6mm. This joint is often used in sheet metal work. It is suitable for severe loading.

### **4. T – joint**

It is used to weld two perpendicular plates. This is economical for joining thin plates up to 3mm. This joint is often used in structures.

### **5. Corner joint**

It is used to join the edges of two pieces whose surfaces are approximately at right angles to each other. It is common in the construction of boxes, tanks, frames and other similar items. Edge preparation is not necessary for these joints.

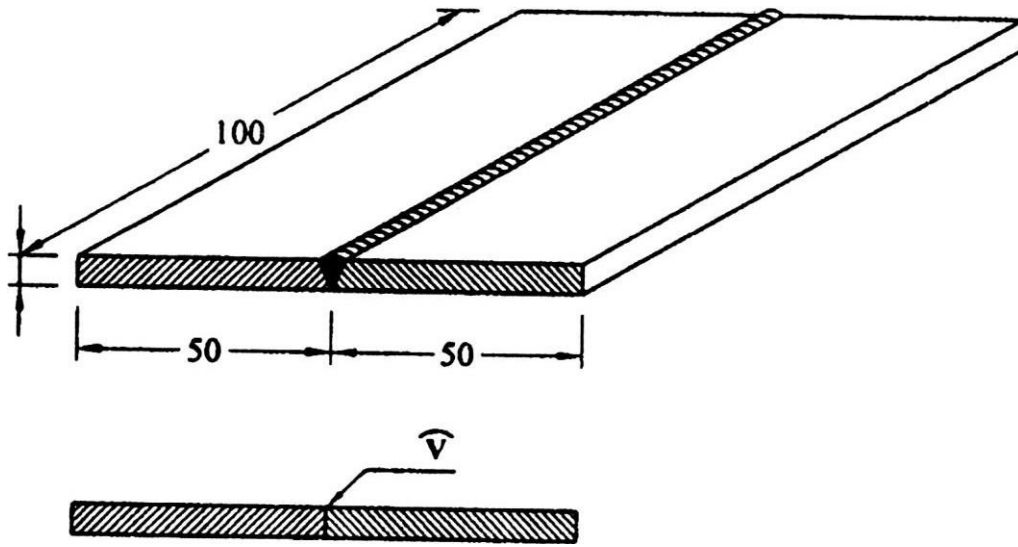

All Dimensions in mm



## 1. BUTT JOINT

### **Aim:**

To make a butt joint on the given work pieces using arc welding.

### **Apparatus required:**

Work pieces, Welding electrodes, Welding machine, Tongs, Wire brush, chipping hammer, Gloves and Goggles.

### **Procedure:**

1. The given work pieces are cleaned with the wire brush to remove the rust, scale and other impurities.
2. Edges are prepared suitably to the given dimension and positioned for the butt joint.
3. Depending upon the thickness of the parent metal, the amperage and correct voltage is selected.
4. With goggles covering the eyes and gloves on hands, an arc is struck on the work piece and tacks are made at the extreme ends.
5. Welding process is progressed along the seam at a constant speed and keeping uniform distance between the electrode and the work piece.
6. Using chipping hammer the flux in the form of slag is chipped off and then cleaned.
7. After welding, the work pieces should be handles only using the tongs.

### **Result:**

Thus the required butt joint is obtained as per the given dimensions.

## VIVA QUESTIONS AND ANSWERS

1. Name the types of welding.

(i) Arc welding (ii) Argon welding (Iii) Gas welding (iv) Tig welding (v) Mig welding (vi)

Spot welding

2. Which is are the types of joint?

Butt joint, T - joint, Lap joint.

3. What is welding?

Joining of two similar metals

4. Name the welding tools used in workshop.

Welding holder, welding rod, hand shield, hand gloves, chipping hammer, wire brush

5. Which outer cover is on the welding rod?

Silicon

6. What is the use of welding holder?

It hold the electrode firmly.

7. What is the use of hand shield?

It protects the face from sparks.

8. What is the use of hand gloves?

It protects the hands from sparks.

9. What is the use of chipping hammer?

It is used to remove the waste material from welded metal.

10. What is the use of wire brush?

It is used to clean the outer surface of welded metal.

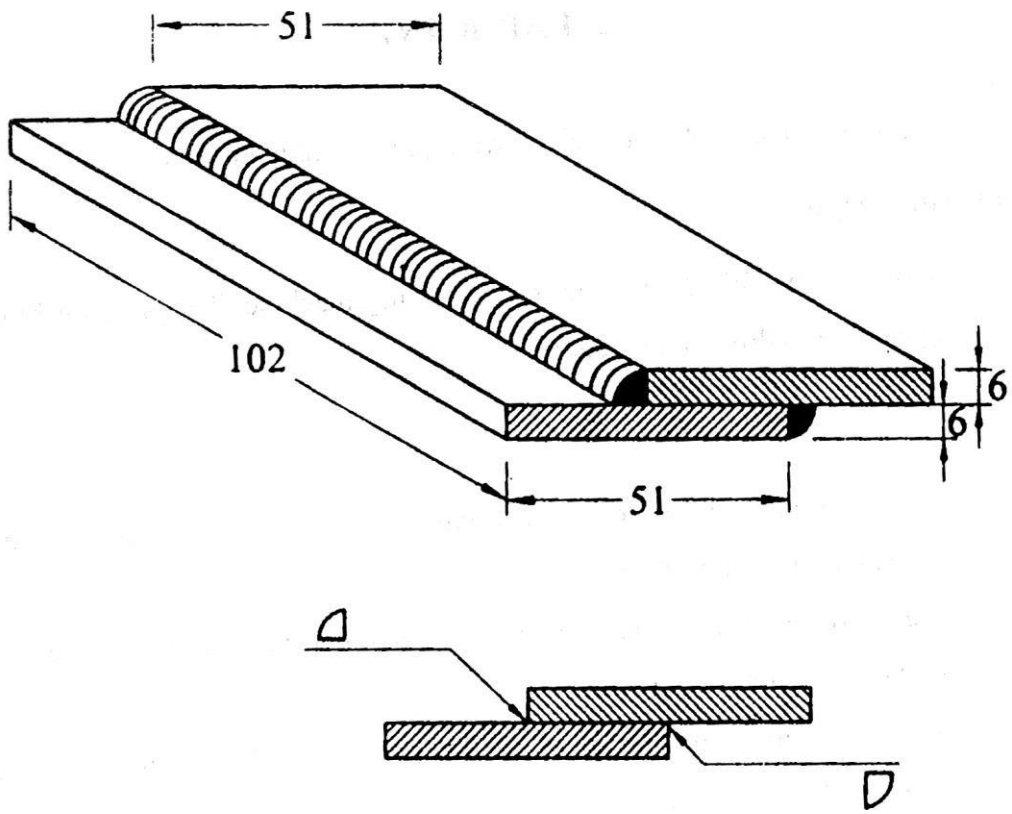

All Dimensions in mm

## 2. LAP JOINT

### **Aim:**

To make a lap joint on the given work pieces using arc welding.

### **Apparatus required:**

Work pieces, Welding electrodes, Welding machine, Tongs, Wire brush, chipping hammer, Gloves and Goggles.

### **Procedure:**

1. The given work pieces are cleaned with the wire brush to remove the rust, scale and other impurities.
2. Edges are prepared suitably to the given dimension and positioned one over another for the lap joint.
3. Depending upon the thickness of the parent metal, the amperage and correct voltage is selected.
4. With goggles covering the eyes and gloves on hands, an arc is struck on the work piece and tacks are made at the extreme ends.
5. Welding process is progressed along the seam at a constant speed and keeping uniform distance between the electrode and the work piece.
6. Using chipping hammer the flux in the form of slag is chipped off and then cleaned.
7. After welding, the work pieces should be handles only using the tongs.

### **Result:**

Thus the required lap joint is obtained as per the given dimensions.

## VIVA QUESTIONS AND ANSWERS

1. Which welding process uses non-consumable electrodes?

TIG welding

2. What is gas welding?

Mixture of gases is used to produce high temperature flame.

3. What is filler material?

It is the material added to the weld pool to assist in filling the gap.

4. What is flux?

Flux avoids oxidation in welding flame by giving a cover.

5. What are the advantages of using LPG over acetylene for cutting?

LPG fuel produces rich flame for cutting process.

6. Which equipment is used to supply power for welding?

Welding transformer

7. What is over head welding?

Welding done at the top of welding booth is called overhead welding.

8. What are the applications of welding?

Fabrication of steel windows and rods.

9. What is flux change in welding?

Flux change is done to switch from one type of welding to other.

10. What are the advantages of using electric arc welding?

EAW can be done without the use of oxygen cylinder.

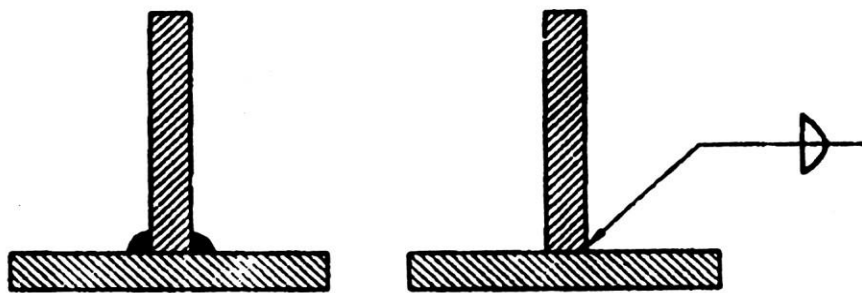
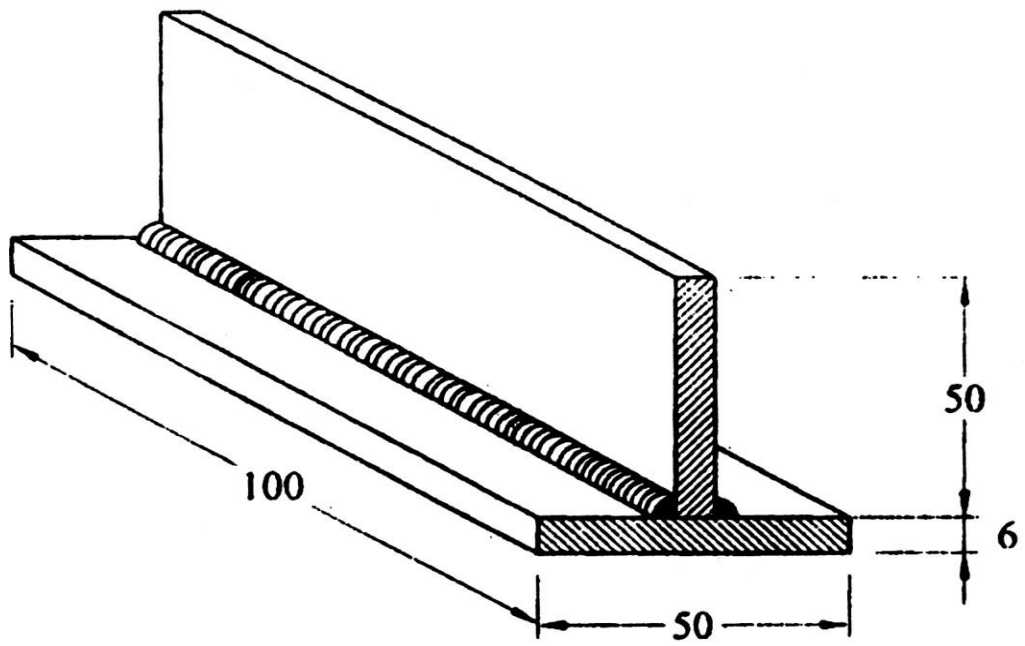

**Welded Joint Representation**

All Dimensions in mm

### 3. T - JOINT

**Aim:**

To make a T - joint on the given work pieces using arc welding.

**Apparatus required:**

Work pieces, Welding electrodes, Welding machine, Tongs, Wire brush, chipping hammer, Gloves and Goggles.

**Procedure:**

1. The given work pieces are cleaned with the wire brush to remove the rust, scale and other impurities.
2. Edges are prepared suitably to the given dimension and positioned at right angles for the tee joint.
3. Depending upon the thickness of the parent metal, the amperage and correct voltage is selected.
4. With goggles covering the eyes and gloves on hands, an arc is struck on the work piece and tacks are made at the extreme ends.
5. Welding process is progressed along the seam at a constant speed and keeping uniform distance between the electrode and the work piece.
6. Using chipping hammer the flux in the form of slag is chipped off and then cleaned.
7. After welding, the work pieces should be handles only using the tongs.

**Result:**

Thus the required T - joint is obtained as per the given dimensions.

## VIVA QUESTIONS AND ANSWERS

1. What is arc welding?

Electric arc is produced between carbon electrode and work piece to produce heat.

2. What is electrode?

Filler rods used in arc welding are called electrodes.

3. Name the materials used for coating on electrodes.

Copper, Carbon and Graphite.

4. What are the types of resistance welding?

Spot welding, Projection welding and Butt welding.

5. What are the welding defects?

Undercut, Cracking and Incomplete penetration.

6. What is coating done on electrode surface?

Coating is done to avoid melting of electrode.

7. What is butt joint?

Work pieces are welded to either sides.

8. What is lap joint?

Work pieces are welded one over other.

9. What is T- joint?

Work pieces are welded at perpendicular to each other.

10. What is corner joint?

Work pieces are welded at the corners.



LATHE

## **LATHE**

The lathe is used for producing cylindrical work. The work piece is rotated while the cutting tool movement is controlled by the machine. The lathe is primarily used for cylindrical work. The lathe may also be used for: Boring, drilling, tapping, turning, facing, threading, polishing, grooving, knurling etc.

The purpose of a lathe is to rotate a part against a tool whose position it controls. It is useful for fabricating parts and/or features that have a circular cross section. The spindle is the part of the lathe that rotates. Various work holding attachments such as three jaw chucks, collets, and centers can be held in the spindle. The spindle is driven by an electric motor through a system of belt drives and/or gear trains. Spindle speed is controlled by varying the geometry of the drive train.

The tailstock can be used to support the end of the work piece with a center, or to hold tools for drilling, reaming, threading, or cutting tapers. It can be adjusted in position along the ways to accommodate different length work pieces. The ram can be fed along the axis of rotation with the tailstock hand wheel.

The carriage controls and supports the cutting tool. It consists of: A saddle that mates with and slides along the ways, an apron that controls the feed mechanisms, a cross slide that controls transverse motion of the tool (toward or away from the operator), a tool compound that adjusts to permit angular tool movement and a tool post T-slot that holds the tool post.

### **Feed, Speed, And Depth of Cut**

Cutting speed is defined as the speed at which the work moves with respect to the tool. Feed rate is defined as the distance the tool travels during one revolution of the part. Cutting speed and feed determines the surface finish, power requirements, and material removal rate. The primary factor in choosing feed and speed is the material to be cut. However, one should also consider material of the tool, rigidity of the work piece, size and condition of the lathe, and depth of cut. To calculate the proper spindle speed, divide the desired cutting speed by the circumference of the work.

## Parts of Lathe

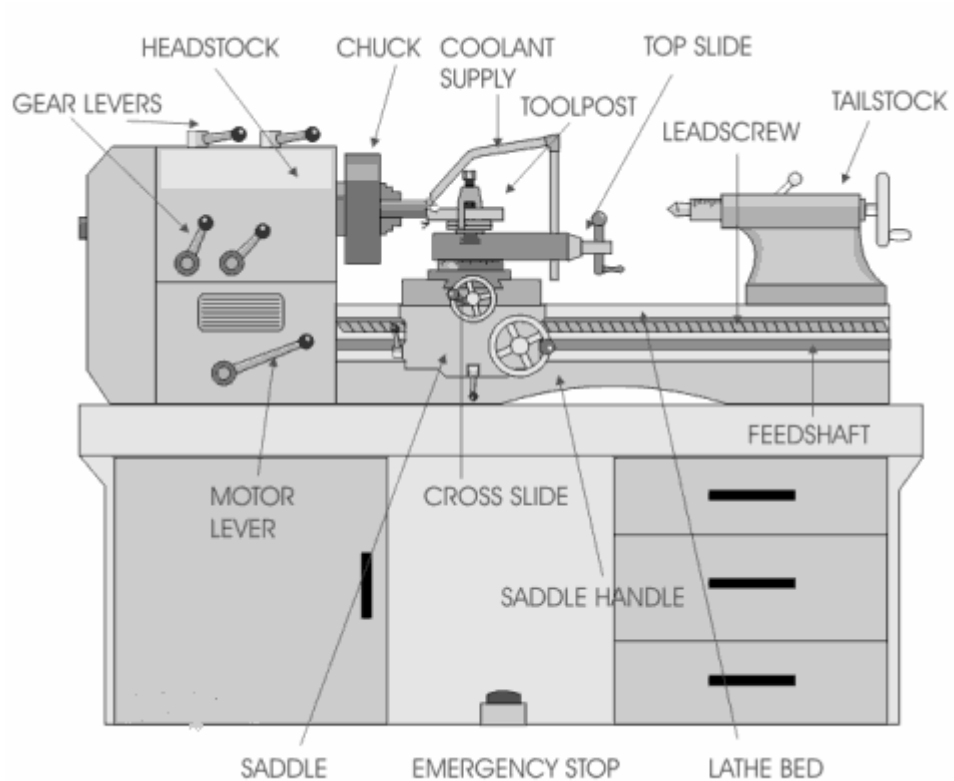

## Head Stock

The headstock houses the main spindle, speed change mechanism, and change gears. The headstock is required to be made as robust as possible due to the cutting forces involved, which can distort a lightly built housing, and induce harmonic vibrations that will transfer through to the work piece, reducing the quality of the finished work piece.

## Bed

The bed is a robust base that connects to the headstock and permits the carriage and tailstock to be aligned parallel with the axis of the spindle. This is facilitated by hardened and ground ways which restrain the carriage and tailstock in a set track. The carriage travels by means of a rack and pinion system, leadscrew of accurate pitch, or feed screw.

## **Feed and lead screws**

The feed screw is a long driveshaft that allows a series of gears to drive the carriage mechanisms. These gears are located in the apron of the carriage. Both the feed screw and lead screw are driven by either the change gears or an intermediate gearbox known as a quick change gearbox or Norton gearbox. These intermediate gears allow the correct ratio and direction to be set for cutting threads or worm gears. Tumbler gears are provided between the spindle and gear train that enables the gear train of the correct ratio and direction to be introduced. This provides a constant relationship between the number of turns the spindle makes, to the number of turns the lead screw makes. This ratio allows screw threads to be cut on the work piece without the aid of a die.

## **Carriage**

In its simplest form the carriage holds the tool bit and moves it longitudinally (turning) or perpendicularly (facing) under the control of the operator. The operator moves the carriage manually via the hand wheel or automatically by engaging the feed screw with the carriage feed mechanism, this provides some relief for the operator as the movement of the carriage becomes power assisted. The hand wheels on the carriage and its related slides are usually calibrated both for ease of use and to assist in making reproducible cuts.

## **Cross-slide**

The cross-slide stands atop the carriage and has a lead screw that travels perpendicular to the main spindle axis, this permit facing operations to be performed. This lead screw can be engaged with the feed screw (mentioned previously) to provide automated movement to the cross-slide; only one direction can be engaged at a time as an interlock mechanism will shut out the second gear train.

## **Compound rest**

The compound rest is the part of the machine where the tool post is mounted. It provides a smaller amount of movement along its axis via another lead screw. The compound rest axis can be adjusted independently of the carriage or cross-slide. It is utilized when turning tapers, when screw cutting or to obtain finer feeds than the lead screw normally permits.

## **Tool post**

The tool bit is mounted in the tool post which may be of the American lantern style, traditional 4 sided square styles, or in a quick change style. The advantage of a quick change set-up is to allow an unlimited number of tools to be used (up to the number of holders available) rather than being limited to 1 tool with the lantern style, or 3 to 4 tools with the 4 sided type.

## **Tail Stock**

The tailstock is a tool holder directly mounted on the spindle axis, opposite the headstock. The spindle does not rotate but does travel longitudinally under the action of a lead screw and hand wheel. The spindle includes a taper to hold drill bits, centers and other tooling. The tailstock can be positioned along the bed and clamped in position as required. There is also provision to offset the tailstock from the spindle axis; this is useful for turning small tapers.

## **Lathe Operations**

### **Turning**

Turning is the machining operation that produces cylindrical parts. In its basic form, it can be defined as the machining of an external surface:

- with the work piece rotating,
- with a single-point cutting tool, and
- with the cutting tool feeding parallel to the axis of the work piece and at a distance that will remove the outer surface of the work.

Taper turning is practically the same, except that the cutter path is at an angle to the work axis. Similarly, in contour turning, the distance of the cutter from the work axis is varied to produce the desired shape

### **Facing**

Facing is the producing of a flat surface as the result of a tool's being fed across the end of the rotating work piece. Unless the work is held on a mandrel, if both ends of the work are to be faced, it must be turned end for end after the first end is completed and the facing operation repeated. The cutting speed should be determined from the largest diameter of the surface to be faced. Facing may be

done either from the outside inward or from the center outward. In either case, the point of the tool must be set exactly at the height of the center of rotation.

### **Parting**

Parting is the operation by which one section of a work piece is severed from the remainder by means of a cutoff tool. Because cutting tools are quite thin and must have considerable overhang, this process is less accurate and more difficult. The tool should be set exactly at the height of the axis of rotation, be kept sharp, have proper clearance angles, and be fed into the work piece at a proper and uniform feed rate.

### **Drilling**

A lathe can also be used to drill holes accurately concentric with the centerline of a cylindrical part. First, install a drill chuck into the tail stock. Make certain that the tang on the back of the drill chuck seats properly in the tail stock. Withdraw the jaws of the chuck and tap the chuck in place with a soft hammer.

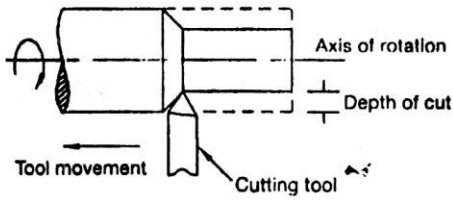

**Turning**

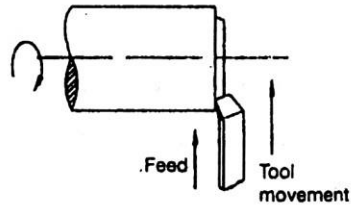

**Facing**

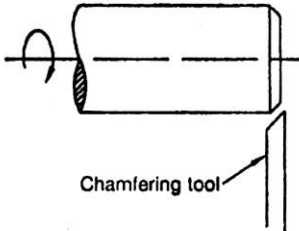

**Chamfering**

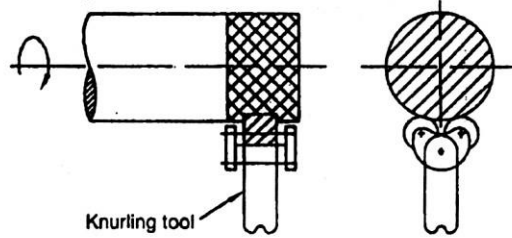

**Knurling**

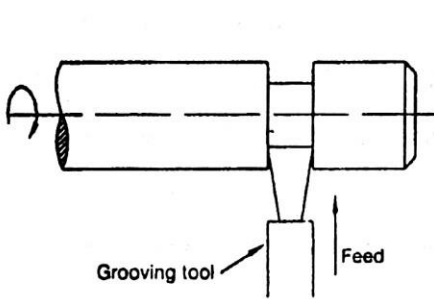

**Grooving**

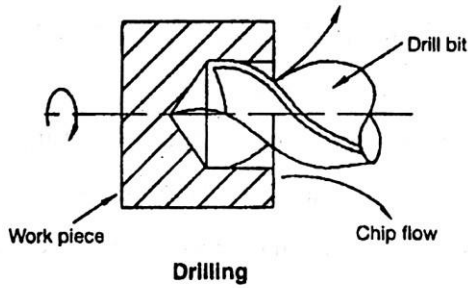

**Drilling**

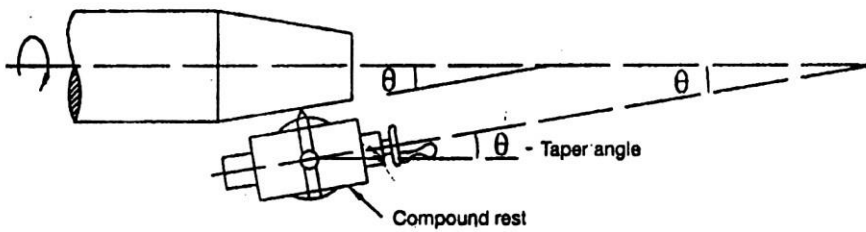

**Taper Turning**

Move the saddle forward to make room for the tailstock. Move the tailstock into position, and lock the bit in place. Before starting the machine, turn the spindle by hand. Just move the saddle forward, so it could interfere with the rotation of the lathe chuck. Always use a center drill to start the hole. .

## **Boring**

Boring is an operation in which a hole is enlarged with a single point cutting tool. A boring bar is used to support the cutting tool as it extends into the hole. Because of the extension of the boring bar, the tool is supported less rigidly and is more likely to chatter. This can be corrected by using slower spindle speeds or by grinding a smaller radius on the nose of the tool.

## **Single Point Thread Turning**

External threads can be cut with a die and internal threads can be cut with a tap. But for some diameters, no die or tap is available. In these cases, threads can be cut on a lathe. A special cutting tool should be used, typically with a 60 degree nose angle. To form threads with a specified number of threads per inch, the spindle is mechanically coupled to the carriage lead screw. Procedures vary for different machines



# Drilling Machine

The machine which performs the drilling operation is known as drilling machine. There are two types of machine drill, the bench drill and the pillar drill. The bench drill is used for drilling holes through materials including a range of woods, plastics and metals. It is normally bolted to a bench so that it cannot be pushed over and that larger pieces of material can be drilled safely.

The larger version of the machine drill is called the pillar drill. This has a long column which stands on the floor. This can do exactly the same work as the bench drill but because of its larger size it is capable of being used to drill larger pieces of materials and produce larger holes.

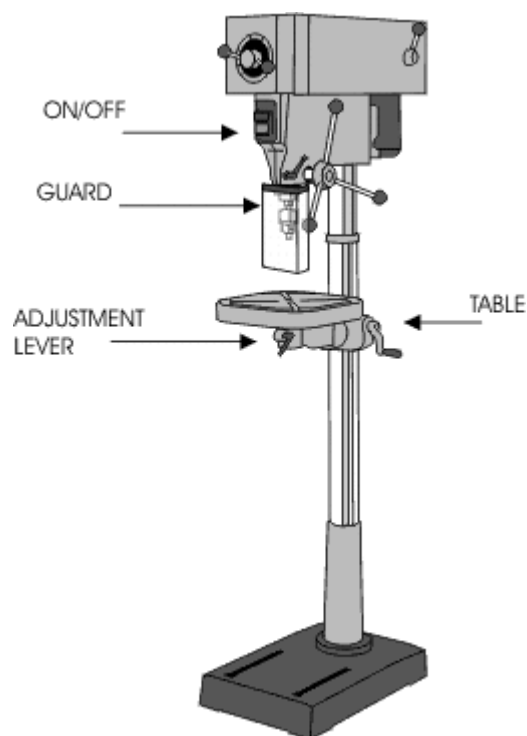

## **SAFETY MEASURES**

1. Always use the guard.
2. Wear goggles when drilling materials.
3. Clamp the materials down or use a machine vice.

4. Never hold materials by hand while drilling.
5. Always allow the 'chippings' to clear the drill by drilling a small amount at a time.
6. Follow all teacher instructions carefully.

## **TYPES OF DRILLING MACHINE**

1. Portable drilling machine
2. Sensitive drilling machine
3. Upright drilling machine
4. Radial drilling machine
5. Gang drilling machine
6. Multi spindle drilling machine

### **Bench Drill**

The bench drill is a smaller version of the pillar drill. This type of machine drill is used for drilling light weight pieces of material. The work piece is held safely in a hand vice which is held in the hand. NEVER hold work directly in the hand when drilling. The on and off buttons are found on the left hand side of the machine and the handle controlling the movement of the drill on the right. Most bench drills will also have a foot switch for turning off the drill. The hand vice is one safe way of holding material whilst drilling. It has two jaws that are closed by turning a wing nut.

### **Drilling Operations**

#### **1. Drilling**

It is the operation by which circular holes can be produced by rotating a tool called drill bit against the work piece. Using centre punch the centre of the hole is marked before drilling. The hole produced by drilling will be rough and of less accuracy.

#### **2. Reaming**

It is the operation of finishing and sizing the already drilled hole. The tool used is called reamer. It removes very little amount of metal to finish the hole.

### **3. Boring**

The operation to enlarge the drilled hole is called boring. For boring, the cutter is held in a boring bar and is fixed to the spindle. It gives good surface finish.

### **4. Counter boring**

To seat the heads of socket, screw and studs, a drilled hole is enlarged to a given depth. This operation is called counter boring.

### **5. Counter sinking**

The operation of machining a conical enlargement at the top of a drilled hole is called counter sinking.

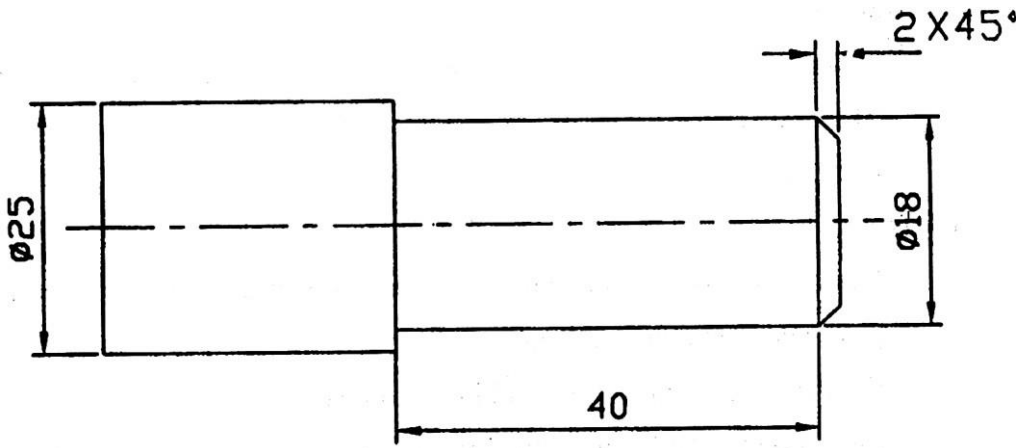

All Dimensions in mm

## 1. TURNING, FACING AND CHAMFERING

**Aim** To perform turning, facing and chamfering on a cylindrical work piece

### Tools Required

1. Lathe
2. Three jaw chuck
3. Chuck key
4. Single point cutting tool
5. Vernier caliper

### Procedure

1. Loosen the jaws in the chuck using chuck key to position the work piece and then tighten the jaws.
2. Fix the single point cutting tool in the tool post
3. Switch on the lathe, move the carriage near the work piece and give a small cross feed. Move the carriage slowly to the required length
4. Bring the carriage to the original position, give a small cross feed and repeat the steps until the required diameter is obtained. At the end give very small feed to get smooth surface.
5. For facing operation, the cutting tool is tilted by  $30^\circ$  and move the carriage to make the tool touch the end surface of the work piece.
6. Give small feed in longitudinal direction and then move the tool inwards using cross slide.
7. For chamfering operation, set the cross slide to  $45^\circ$ , give small feed in longitudinal direction and then move the tool using cross slide.
8. Check the dimensions regularly using vernier caliper.

### Result

Thus the turning, facing and chamfering operations are carried out on the given work piece

## VIVA QUESTIONS AND ANSWERS

1. What is a lathe?

Lathe is a machine, which removes the metal from a piece of work to the required shape and size.

2. What are the various operations that can be performed on a lathe?

Turning, Facing, Chamfering, Drilling, Thread cutting, Grooving, Knurling and Tapping

3. What are the principal parts of a lathe?

Bed, headstock, tailstock, carriage, cross slide, tool post

4. What are the types of headstock?

Back geared type, all geared type

5. State the various parts mounted on the carriage.

Saddle, compound rest, cross slide, tool post

6. What are the four types of tool post?

1. Single screw
2. Open side
3. Four bolt
4. Four way

7. What is a Chamfering?

A cut that is made on the edge of work piece at 45 degree angle to the adjacent principal faces.

8. State any two specifications of a lathe.

1. The height of centers from the bed
2. The maximum length of the bed

9. List any three types of lathe.

1. Engine lathe
2. Bench lathe
3. Tool room lathe

10. What is a semi-automatic lathe?

The lathe in which all the machining operations are performed automatically and loading and unloading of work piece, coolant on or off is performed manually

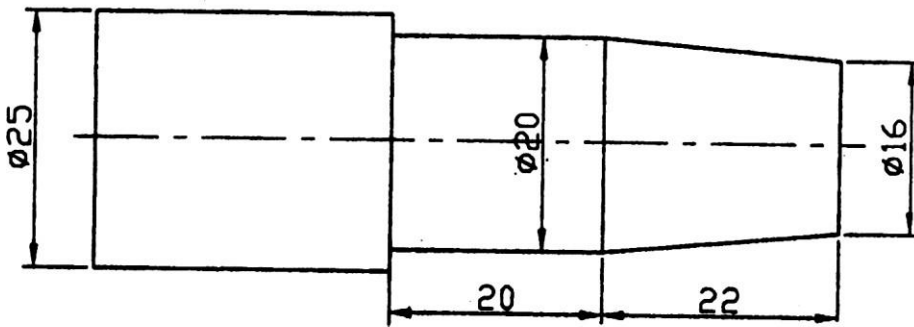

$$\text{Taper angle } \tan \theta = \frac{D - d}{2L}$$

D – Larger diameter of taper

d – Smaller diameter of taper

L – Tapered length

All Dimensions in "mm"

## 2. TAPER TURNING

### Aim

To perform taper turning operation on a cylindrical work piece

### Tools Required

1. Lathe
2. Three jaw chuck
3. Chuck key
4. Single point cutting tool
5. Vernier caliper

### Procedure

1. Loosen the jaws in the chuck using chuck key to position the work piece and then tighten the jaws.
2. Fix the single point cutting tool in the tool post
3. Switch on the lathe, move the carriage near the work piece and give a small cross feed. Move the carriage slowly to the required length
4. Bring the carriage to the original position, give a small cross feed and repeat the steps until the required diameter is obtained. At the end give very small feed to get smooth surface.
5. To produce a taper, rotate and set the cross slide to the required angle.
6. Give a small feed and then move the tool using the cross slide. Repeat the steps to complete the taper.
7. Check the dimensions regularly using vernier caliper.

### Result

Thus the taper turning operation is carried out on the given work piece



## VIVA QUESTIONS AND ANSWERS

1. What is copying lathe?

The tool of the lathe follows a template or master through a stylus or tracer

2. State the various feed mechanisms used for obtaining automatic feed.

- a. Tumbler gear mechanism
- b. Quick change gearbox
- c. Tumbler gear- Quick change gearbox

3. List any four holding devices.

- d. Chucks
- e. Centers
- f. Face plate
- g. Angle plate

4. What are the different operations performed on the lathe?

Centering, straight turning, rough turning, finish turning, shoulder turning, facing, chamfering, knurling, etc

5. Define the term 'Conicity'.

The ratio of the difference in diameters of taper to its length  $k = (D-d)/l$

d-smaller dia D-bigger dia  
l-length of the work piece.

6. What is the use of chuck?

Chuck is used to hold the work piece firmly.

7. What are the types of chuck based on numbering?

Three jaw and four jaw Chuck.

8. What is the use of tail stock?

Tail stock is used to support the rear end of work piece.

9. Where is the motor located in lathe?

It is adjacent to the head stock.

10. What is the use of knurling?

It is to provide grip to the work piece.

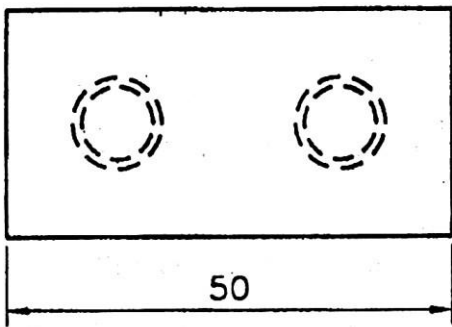
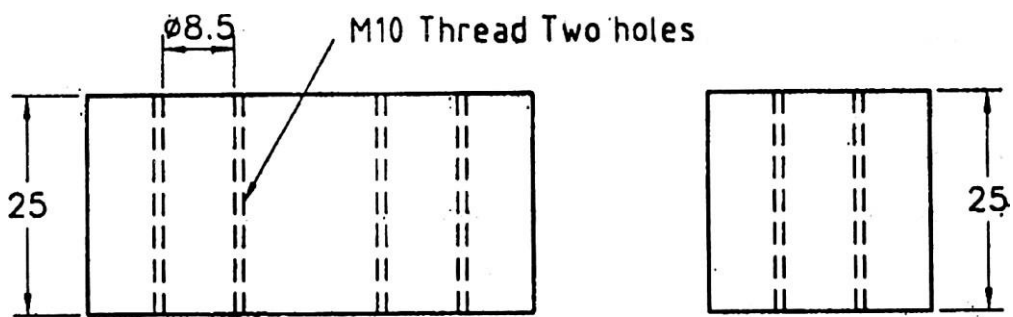

Dimensions After Machining All Dimensions in "mm"

### 3. DRILLING AND TAPPING

**Aim:**

To make an internal thread on a given work piece as per the required dimensions using drilling machine and tapping tool.

**Tools Required:**

- |                 |                     |
|-----------------|---------------------|
| 1. Machine vice | 2. Drilling machine |
| 3. Drill bit    | 4. Tapping tool     |
| 5. Dot punch    | 6. Hammer etc.      |

**Procedure:**

1. The dimensions of the given work piece is checked as per the requirement.
2. The work piece is clamped in the vice and any two surfaces are filed to get right angle.
3. Drill bit of required size is fitted in the drill chuck of the drilling machine.
4. The mid point of the required hole is punched by using dot punch and hammer.
5. The punched dot is drilled by drilling machine.
6. After drilling the hole, they are tapped by using tap tool.
7. Finally the dimensions are checked.

**Result:**

Thus the given work piece is drilled and tapped to the required dimensions.

## VIVA QUESTIONS AND ANSWERS

1. What is the use of drilling machine?

It used to makes holes of required size in work pieces.

2. What are the drilling operations?

Drilling, reaming, boring, counter boring and counter sinking.

3. What is Reaming?

It is the operation of finishing and sizing the already drilled hole. The tool used is called reamer. It removes very little amount of metal to finish the hole.

4. What is Boring?

The operation to enlarge the drilled hole is called boring. For boring, the cutter is held in a boring bar and is fixed to the spindle. It gives good surface finish.

5. What is counter boring?

To seat the heads of socket, screw and studs, a drilled hole is enlarged to a given depth. This operation is called counter boring.

6. What is counter sinking?

The operation of machining a conical enlargement at the top of a drilled hole is called counter sinking.

7. What is the use of a guard?

It is used to protect the face from chips.

8. What is radial drilling machine?

The work piece is drilled at right angles to the drill bit.

9. Why is boring operation preferred?

Varying size of holes can be made from standard sizes.

10. Mention few applications of drilling.

Building construction, tool fabrication etc.

**FOUNDRY  
&  
SMITHY**

## FOUNDRY

A foundry is a factory which produces metal castings from either ferrous or non-ferrous alloys. Metals are turned into parts by melting the metal into a liquid, pouring the metal in a mold, and then removing the mold material or casting. The most common metal alloys produced are aluminum and cast iron. However, other metals, such as steel, magnesium, copper, tin, and zinc, can be processed.

A sand casting or a sand molded casting is a cast part produced by forming a mold from a sand mixture and pouring molten liquid metal into the cavity in the mold. The mold is then cooled until the metal has solidified. In the last stage the casting is separated from the mold. There are six steps in this process:

1. Place a pattern in sand to create a mold.
2. Incorporate a gating system.
3. Remove the pattern.
4. Fill the mold cavity with molten metal.
5. Allow the metal to cool.
6. Break away the sand mold and remove the casting.

There are two main types of sand used for molding. "Green sand" is a mixture of silica sand, clay, moisture and other additives. The "air set" method uses dry sand bonded to materials other than clay, using a fast curing adhesive. When these are used, they are collectively called "air set" sand castings to distinguish these from "green sand" castings. Two types of molding sand are natural bonded (bank sand) and synthetic (lake sand), which is generally preferred due to its more consistent composition.

## A METAL CASTING POURED IN A SAND MOLD

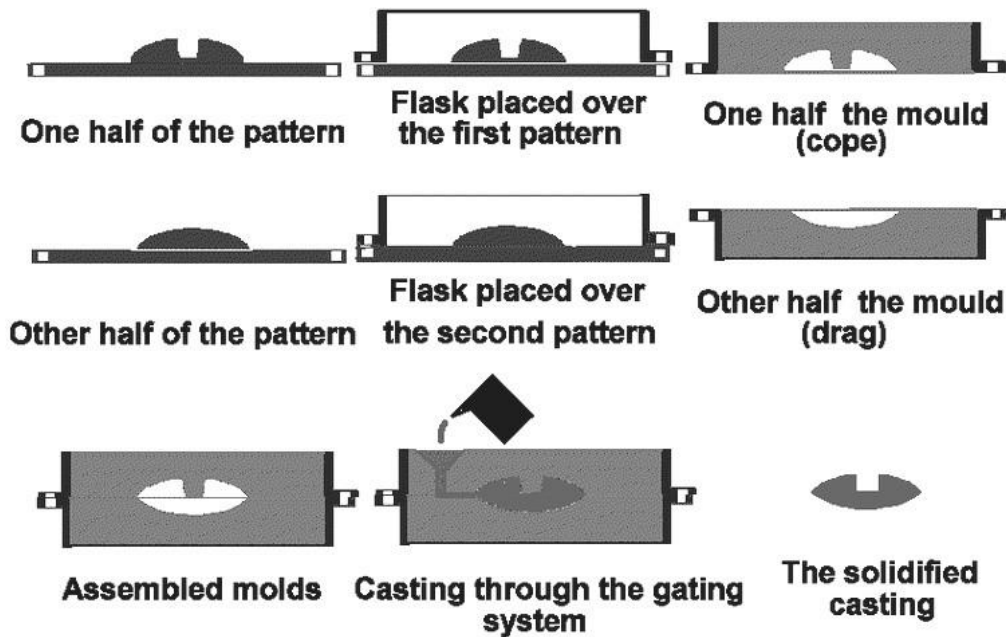

### Foundry hand tools

The hand tools commonly used in foundry are as follows.

#### 1. Shovel

It is used for mixing molding sand and for filling molding sand into the flask. A shovel is shown in fig. (a)

#### 2. Riddle

Riddle is used for removing foreign materials from the moulding sand. It is shown in fig. (b)

#### 3. Rammer

This is used for packing or ramming the sand into the mould. Hand rammers are shown in fig. (c) For large moulds, machine rammers are used.

#### 4. Trowel

A trowel is used for smoothening the surfaces of the mould. It is shown in fig.(d)

#### 5. Sprue pin

It is a conical wooden pin, which is used while making the mould, for making an opening to pour the molten material into the cavity. A sprue pin is shown in fig. (e).

#### **6. Vent rod**

Vent rod is used for making small holes to permit gases to escape while the molten material is being poured. Fig. (f) shows a vent rod.

#### **7. Draw spike**

This is used for drawing patterns from the sand. It has a loop at one end for pulling up the pattern from the mould. Draw spike is shown in fig. (g)

#### **8. Moulding boxes**

These are also known as moulding flasks. Moulding boxes are rigid frames made of iron or wood to hold the sand. The purpose of the flask is to impart necessary rigidity and strength to the rammed sand. Complete process of moulding is done in the moulding boxes. They are usually made in two parts, which are assembled with each other by pins on either side of the flasks. The top flask is called cope and the bottom flask is called drag. If the boxes are made in three sections then the middle one is called as cheek.



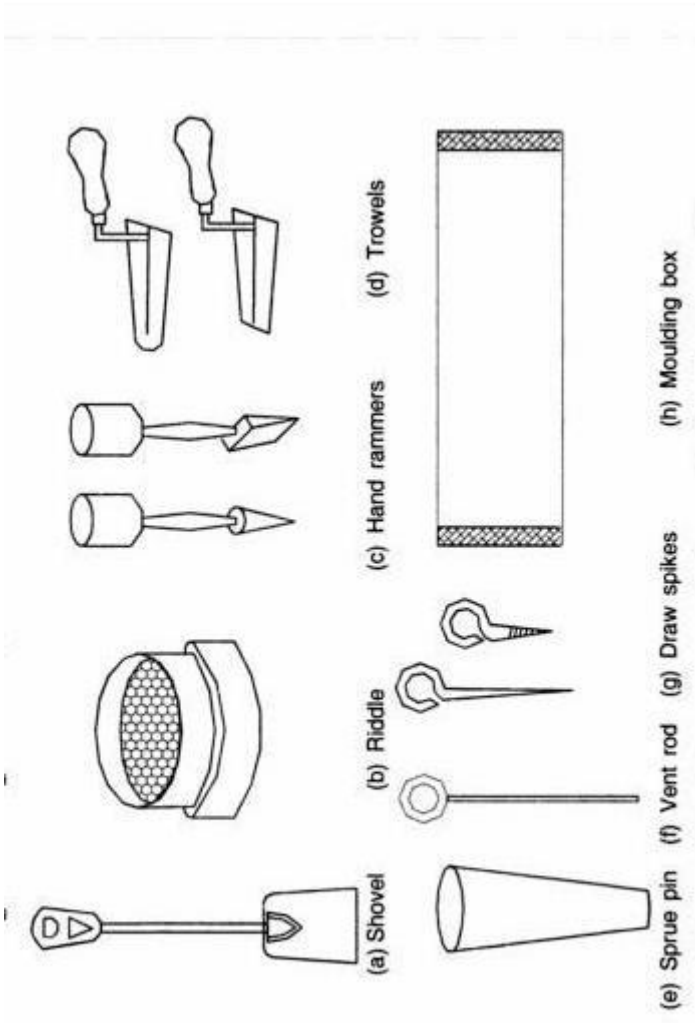

## SMITHY

Black smithy or forging is an ancient trade. It consists of heating a metal stock till it acquires sufficient plasticity, followed by hand forging, involving hammering, bending, pressing etc., till the desired shape is attained.

Hand forging is the term used when the process is carried out by hand tools. The hand forging process is generally employed for relatively small components. If power operated machines are used for the purpose, it is known as machine forging.

### Advantages of forging

1. Strength and toughness is high
2. Strength to weight ratio is high
3. Internal defects are eliminated.

A blacksmith is a person who creates objects from iron or steel by "forging" the metal; i.e., by using tools to hammer, bend, cut, and otherwise shape it in its non-liquid form. Usually the metal is heated until it glows red or orange as part of the forging process. Blacksmiths produce things like wrought iron gates, grills, railings, light fixtures, furniture, sculpture, tools, agricultural implements, decorative and religious items, cooking utensils etc.

### Forging Operations

There are five basic operations or techniques employed in forging: drawing, shrinking, bending, upsetting, and punching.

These operations generally employ hammer and anvil at a minimum, but smiths will also make use of other tools and techniques to accommodate odd-sized or repetitive jobs.

### Drawing

Drawing lengthens the metal by reducing one or both of the other two dimensions. As the depth is reduced, the width narrowed, or both the piece is lengthened or "drawn out". As an example of drawing, a smith making a wood chisel might flatten a square bar of steel, lengthening the metal, reducing its depth but keeping its width consistent.

### Upsetting

Upsetting is the process of making metal thicker in one dimension through shortening in the other. One form is by heating the end of a rod and then hammering on it as one would drive a nail: the rod gets shorter, and the hot part widens. An alternative to hammering on the hot end would be to place the hot end on the anvil and hammer on the cold end, or to drop the rod, hot end down, onto a piece of steel at floor level.

### **Shrinking**

Shrinking, while similar to upsetting, is essentially the opposite process as drawing. As the edge of a flat piece is curved,—as in the making of a bowl shape—the edge will become wavy as the material bunches up in a shorter radius. At this point the wavy portion is heated and the waves are gently pounded flat to conform to the desired shape.

### **Bending**

Heating steel to an orange heat allows bending. Bending can be done with the hammer over the horn or edge of the anvil, or by inserting the work into one of the holes in the top of the anvil and swinging the free end to one side. Bends can be dressed and tightened or widened by hammering them over the appropriately-shaped part of the anvil.

### **Punching**

Punching may be done to create a decorative pattern, or to make a hole. For example, in preparation for making a hammerhead, a smith would punch a hole in a heavy bar or rod for the hammer handle. Punching is not limited to depressions and holes. It also includes cutting, or slitting and drifting: these are done with a chisel.

### **Hand Forging Tools**

All a smith needs is something to heat the metal, [something to hold the hot metal with,] something to hit the metal on, and something to hit the metal with."

### **Anvil**

The anvil at its simplest is a large block of iron or steel. Over time this has been refined to provide a rounded horn to facilitate drawing and bending, a face for drawing and upsetting and bending, and one or more holes to hold special tools (swages or hardies) and facilitate punching. Often the flat surface of an anvil will be hardened steel, and the body made from tougher iron.

### **Tongs**

Tongs are used to hold the hot metal. They come in a range of shapes and sizes. Intriguingly, while tongs are needed for a great deal of blacksmithing, much work can be done by merely holding the cold end with one's bare hand: steel is a fairly poor conductor of heat, and orange-hot steel at one end would be cold to the touch a foot away or so.

## **Hammers**

Blacksmiths' hammers tend to have one face and a peen. The peen is typically either a ball or a blunt wedge (cross or straight peen depending on the orientation of the wedge to the handle) and is used when drawing.

## **Swage block**

Swages (hardies) and fullers are shaping tools. Swages are either stand alone tools or fit the "hardie hole" on the face of the anvil. The metal is shaped by being driven into the form of the swage. Opposite to the swage in some respects is the fuller which may take a number of shapes and is driven into the metal with a hammer. Swages and fullers are often paired to bring a piece of metal to shape in a single operation, essentially a set of dies. A fuller and swage pair might be spoon shaped, for example, the swage dished to form the bowl and the fuller the convex mirror of the swage. Together they will quickly stamp a spoon shape on the end of a bar.

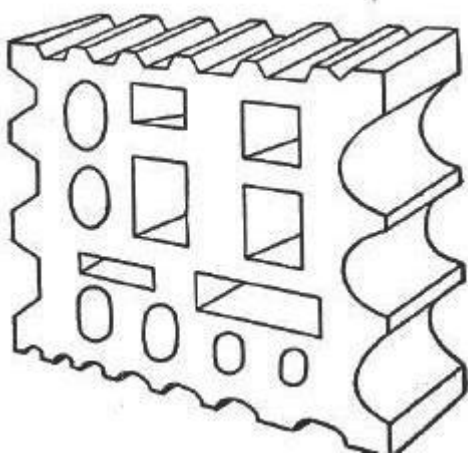

**SWAGE BLOCK**



**FULLER**

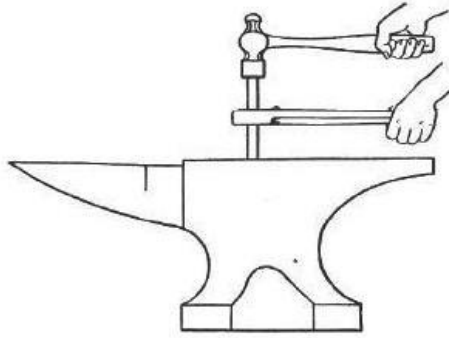

**ANVIL**

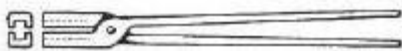
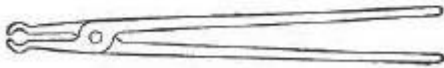
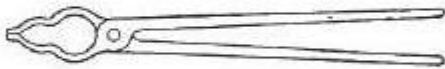
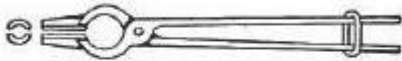
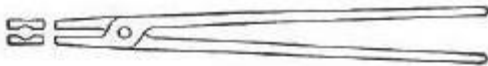

**TONGS**



**A & B - CROSS PEEN HAMMER**

**C - BALL PEEN HAMMER**

**D - STRAIGHT PEEN HAMMER**

# SHEET METAL

## **SHEET METAL**

### **Introduction**

Sheet metal is simply metal formed into thin and flat pieces. It is one of the fundamental forms used in metalworking, and can be cut and bent into a variety of different shapes. Countless everyday objects are constructed of the material. Thicknesses can vary significantly, although extremely thin thicknesses are considered foil or leaf, and pieces thicker than 6 mm (0.25 in) are considered plate.

Sheet metal is available as flat pieces or as a coiled strip. The coils are formed by running a continuous sheet of metal through a roll slitter.

The thickness of the sheet metal is called its gauge. The gauge of sheet metal ranges from 30 gauge to about 8 gauge. The higher the gauge, the thinner the metal is.

There are many different metals that can be made into sheet metal, such as aluminum, brass, copper, steel, tin, nickel and titanium. For decorative uses, important sheet metals include silver, gold, and platinum (platinum sheet metal is also utilized as a catalyst.)

Sheet metal has applications in car bodies, airplane wings, medical tables, roofs for building and many other things. Sheet metal of iron and other materials with high magnetic permeability, also known as laminated steel cores, has applications in transformers and electric machines. Historically, an important use of sheet metal was in plate armor worn by cavalry, and sheet metal continues to have many decorative uses, including in horse tack.

### **Sheet metal processing**

The raw material for sheet metal manufacturing processes is the output of the rolling process. Typically, sheets of metal are sold as flat, rectangular sheets of standard size. If the sheets are thin and very long, they may be in the form of rolls. Therefore the first step in any sheet metal process is to cut the correct shape and sized 'blank' from larger sheet.

## Sheet metal processes

Sheet metal processes can be broken down into two major classifications and one minor classification

- **Shearing processes** - processes which apply shearing forces to cut, fracture, or separate the material.
- **Forming processes** - processes which cause the metal to undergo desired shape changes without failure, excessive thinning, or cracking. This includes bending and stretching.
- **Finishing processes** - processes which are used to improve the final surface characteristics.

### Shearing Process

1. **Punching:** shearing process using a die and punch where the interior portion of the sheared sheet is to be discarded.
2. **Blanking:** shearing process using a die and punch where the exterior portion of the shearing operation is to be discarded.
3. **Perforating:** punching a number of holes in a sheet
4. **Parting:** shearing the sheet into two or more pieces
5. **Notching:** removing pieces from the edges
6. **Lancing:** leaving a tab without removing any material

### Forming Processes

- **Bending:** forming process causes the sheet metal to undergo the desired shape change by bending without failure. Ref fig.
- **Stretching:** forming process causes the sheet metal to undergo the desired shape change by stretching without failure.
- **Drawing:** forming process causes the sheet metal to undergo the desired shape change by drawing without failure.
- **Roll forming:** Roll forming is a process by which a metal strip is progressively bent as it passes through a series of forming rolls.



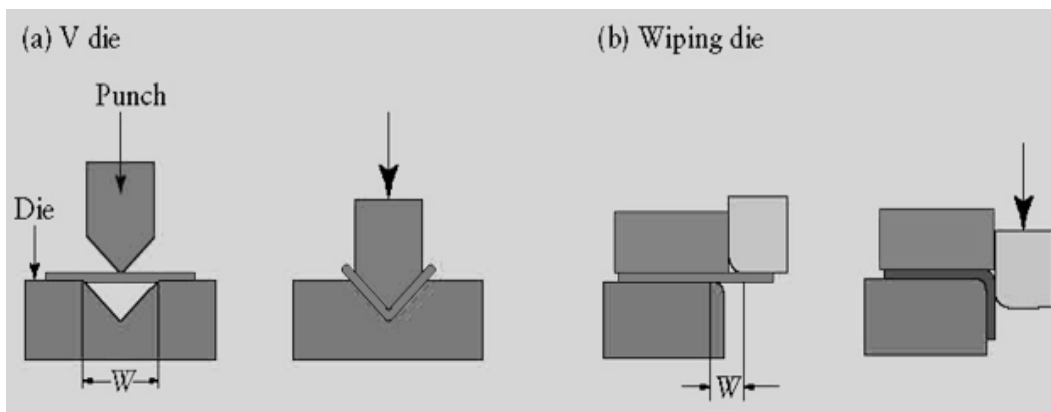

**Common Die – Bending operations**

### **Finishing processes**

Material properties, geometry of the starting material, and the geometry of the desired final product play important roles in determining the best process

### **Equipments**

Basic sheet forming operations involve a press, punch, or ram and a set of dies

### **Presses**

- **Mechanical Press** - The ram is actuated using a flywheel. Stroke motion is not uniform.
- **Hydraulic Press** - Longer strokes than mechanical presses, and develop full force throughout the stroke. Stroke motion is of uniform speed, especially adapted to deep drawing operations.

### **Dies and Punches**

- **Simple**- single operation with a single stroke
- **Compound**- two operations with a single stroke
- **Combination**- two operations at two stations
- **Progressive**- two or more operations at two or more stations with each press stroke, creates what is called a strip development

## Tools and Accessories

The various operations such as cutting, shearing, bending, folding etc. are performed by these tools.

### Marking and measuring tools

- **Steel Rule** - It is used to set out dimensions.
- **Try Square** - Try square is used for making and testing angles of 90degree
- **Scriber** – It used to scribe or mark lines on metal work pieces.
- **Divider** - This is used for marking circles, arcs, laying out perpendicular lines, bisecting lines, etc

### Cutting Tools

- **Straight snip** - They have straight jaws and used for straight line cutting. Ref fig.
- **Curved snip** - They have curved blades for making circular cuts. Ref fig.

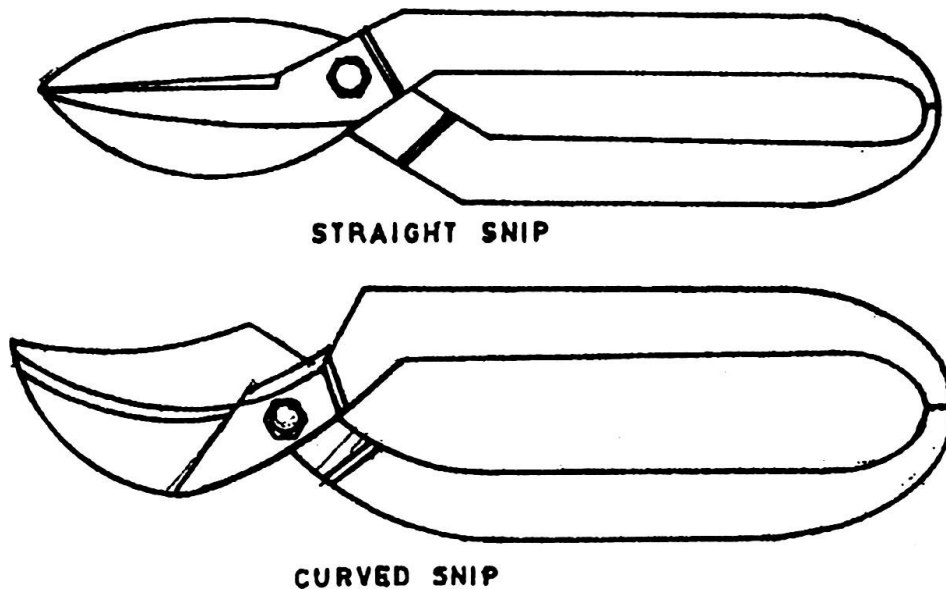

### Striking Tools

**Mallet** - It is wooden-headed hammer of round or rectangular cross section. The striking face is made flat to the work. A mallet is used to give light blows to the Sheet metal in bending and finishing. Ref fig.

**Hammers** – Hammers are also used in sheet metal work for forming shapes. Commonly used hammers are rubber / nylon hammers and creasing hammer.

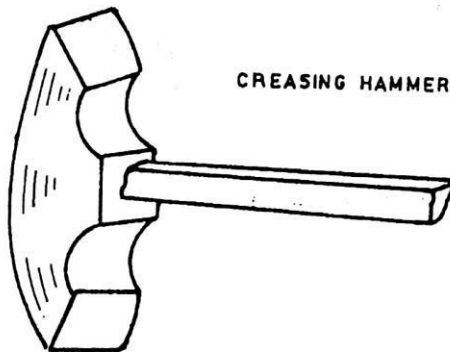
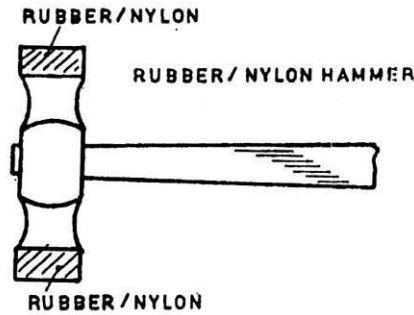
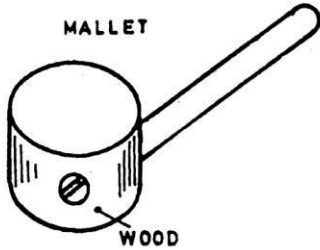
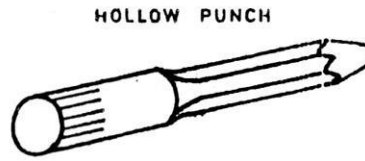

## Merits

High strength

Good dimensional accuracy and surface finish

Relatively low cost

## Demerits

Wrinkling and tearing are typical limits to drawing operations

Different techniques can be used to overcome these limitations

- Draw beads
- Vertical projections and matching grooves in the die and blank holder

Trimming may be used to reach final dimensions

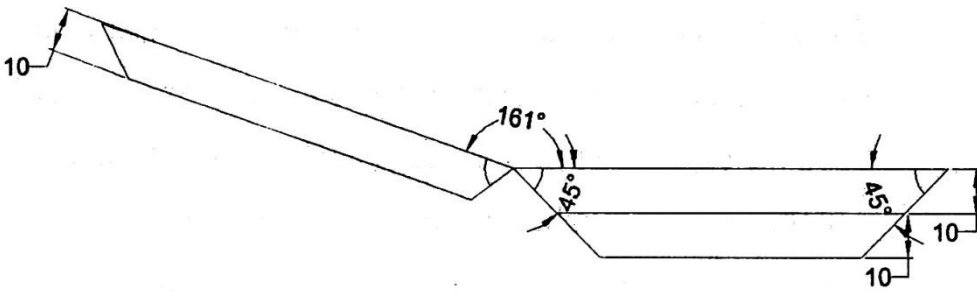
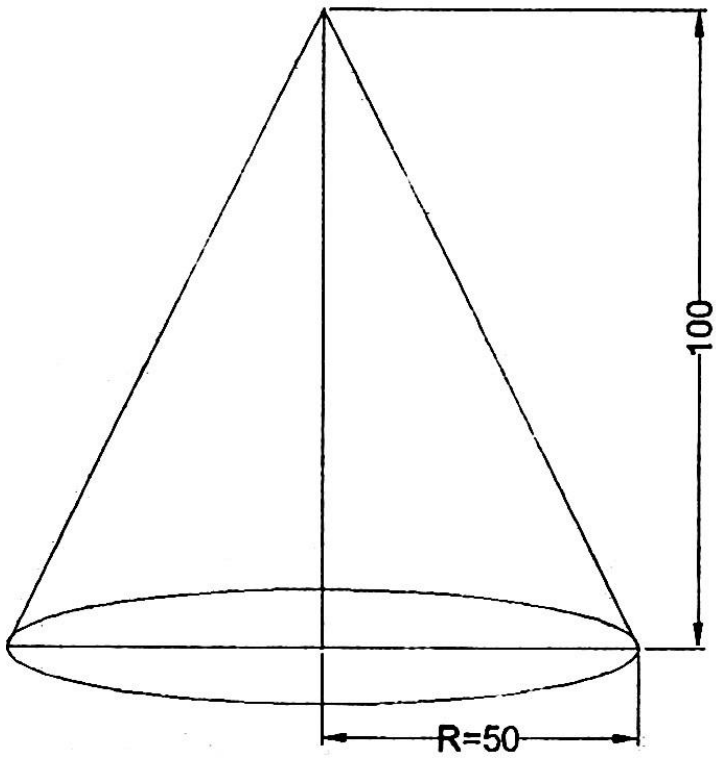

All Dimensions in "mm"

## 1. CONE MAKING

**Aim:** To make a hollow cone out of the given sheet with specified dimensions.

**Tools required:**

- |                     |          |                           |               |
|---------------------|----------|---------------------------|---------------|
| 1. Sheet metal      | 2. Anvil | 3. Try square             | 4. Steel rule |
| 5. Divider          | 6. Snip  | 7. Scriber                |               |
| 8. Mallet           | 9. File  | 10. Hand shearing machine |               |
| 11. Protractor etc. |          |                           |               |

**Materials required:**

Tin or mild steel of suitable size.

**Procedure:**

1. Development of cone for the given dimensions is drawn on the provided sheet metal using protractor and scribe. (Sector of radius equal to the slant length of the cone and arc length equal to the circumference of the cone)
2. Assume, joining allowance of 10 to 15mm on either side of the development.
3. The sheet metal is exactly cut as per the markings made on it using a straight shear / snip. The burrs are removed using a file.
4. Then the edges are bent for a length of joining allowance. This is done with the help of a mallet and an appropriate stake / anvil.
5. The sheet metal is then formed to the conical shape using a cylindrical stake / anvil and a mallet as shown in fig.
6. Now the bent edges are made to overlap each other and are struck with a mallet to get the required joint.

**Result:**

Thus the cone of given dimension is fabricated with the given sheet metal.

## VIVA QUESTIONS AND ANSWERS

1. What is sheet metal work?

Sheet metal work is used for making, Cutting and bending of sheet metals to desired shape.

2. Which are the materials used for sheet metals?

(i) Galvanized iron (ii) Stainless steel (iii) Copper (iv) Aluminium

3. Name the sheet metal hand tools.

(i) Steel rule (ii) Vernier calliper (iii) Micrometer (iv) Scriber (v) Divider (vi) hammer (viii) mallet (ix) Shears

4. What is G.I.?

G.I. is galvanized iron

5. What is shearing?

Shearing means sheet metal cutting

6. What is the name of vice used in fitting shop?

Bench vice

7. Name the different files?

(i) Flat file (ii) Square file (iii) Round file (iv) Triangular file (v) Half round file

8. What are the metals that can be used for sheet metal work?

Aluminium, Brass, Copper and steel.

9. What are the cutting tools?

Straight snip and Curved snip

10. What is Curved snip?

Curved blades are used for making circular cuts.

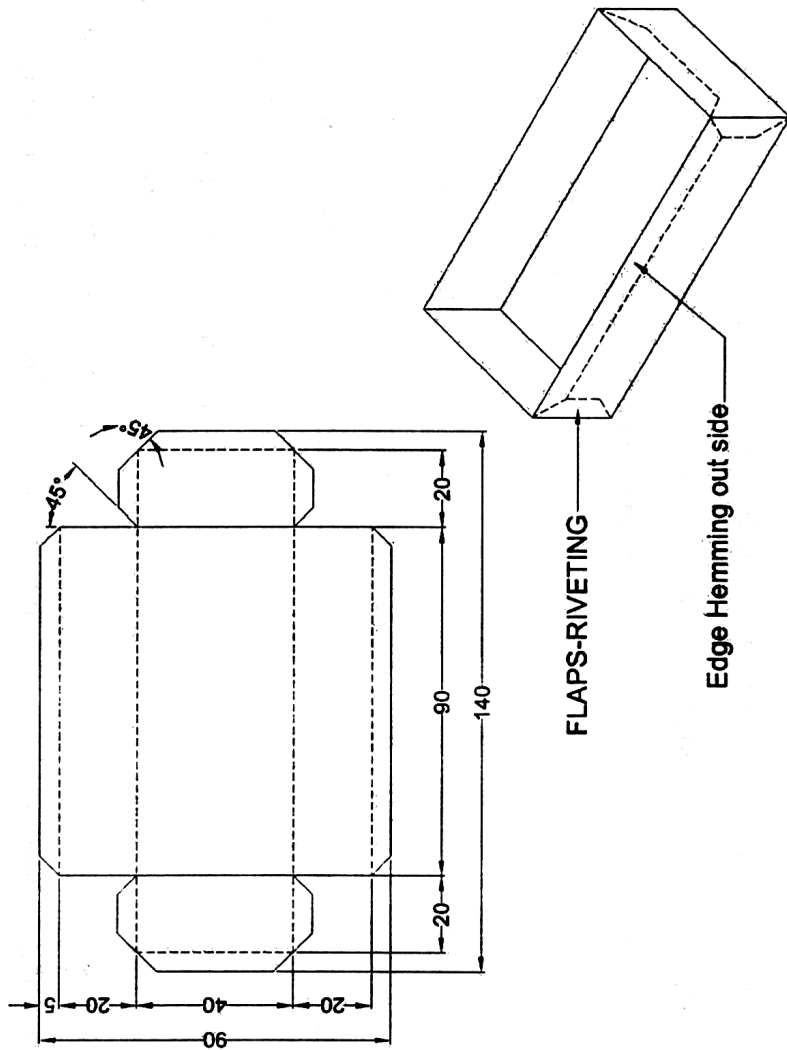

All Dimensions in "mm"

## 2. TRAY MAKING

**Aim:** To make a rectangular tray out of the given sheet with specified dimensions.

**Tools required:**

- |                     |          |                           |               |
|---------------------|----------|---------------------------|---------------|
| 1. Sheet metal      | 2. Anvil | 3. Try square             | 4. Steel rule |
| 5. Divider          | 6. Snip  | 7. Scriber                |               |
| 8. Mallet           | 9. File  | 10. Hand shearing machine |               |
| 11. Protractor etc. |          |                           |               |

**Materials required:**

Tin or mild steel of suitable size.

**Procedure:**

1. Development of the rectangular tray for the given dimensions is drawn on the provided sheet metal using steel rule, protractor and scriber as shown in fig.
2. Assume some joining allowance on all sides of the development for locking the tray.
3. The sheet metal is exactly cut as per the markings made on it using a hand shearing machine or snip. The burrs are removed using a file.
4. Single hemming is made on the four sides of the tray as shown in fig.
5. Four sides are bent to 90° using stake / anvil.
6. Then the edges are bent for the length of joining allowance and the edges are made to overlap each other and are struck with a mallet to get the required joint.

**Result:**

Thus the rectangular tray of given dimension is fabricated with the given sheet metal.



## VIVA QUESTIONS AND ANSWERS

1. What is a try square?

Try square is used for making and testing angles of 90degree

2. What is a Scriber?

It used to scribe or mark lines on metal work pieces.

3. What is a Divider?

This is used for marking circles, arcs, laying out perpendicular lines, bisecting lines, etc

4. What is a straight snip?

They have straight jaws and used for straight line cutting.

5. What is a Mallet?

It is wooden-headed hammer of round or rectangular cross section. The striking face is made flat to the work.

6. What is a Hammer?

Hammer is also used in sheet metal work for forming shapes. Commonly used hammers are rubber / nylon hammers and creasing hammer.

7. What is punching?

It is the shearing process using a die and punch where the interior portion of the sheared sheet is to be discarded.

8. What is Blanking?

Shearing process using a die and punch where the exterior portion of the shearing operation is to be discarded.

9. What is Perforating?

Punching a number of holes in a sheet

10. What is parting?

Shearing the sheet into two or more pieces

## CENTRIFUGAL PUMP

A centrifugal pump is one of the simplest pieces of equipment in any process plant. Its purpose is to convert energy of a prime mover (a electric motor or turbine) first into velocity or kinetic energy and then into pressure energy of a fluid that is being pumped.

The energy changes occur by virtue of two main parts of the pump, the impeller and the volute or diffuser. The impeller is the rotating part that converts driver energy into the kinetic energy. The volute or diffuser is the stationary part that converts the kinetic energy into pressure energy.

Note: All of the forms of energy involved in a liquid flow system are expressed in terms of feet of liquid i.e. head.

### Generation of Centrifugal Force

The process liquid enters the suction nozzle and then into eye (center) of a revolving device known as an impeller. When the impeller rotates, it spins the liquid sitting in the cavities between the vanes outward and provides centrifugal acceleration. As liquid leaves the eye of the impeller, a low-pressure area is created causing more liquid to flow toward the inlet. Because the impeller blades are curved, the fluid is pushed in a tangential and radial direction by the centrifugal force. This force acting inside the pump is the same one that keeps water inside a bucket that is rotating at the end of a string. Figure below depicts a side cross-section of a centrifugal pump indicating the movement of the liquid.

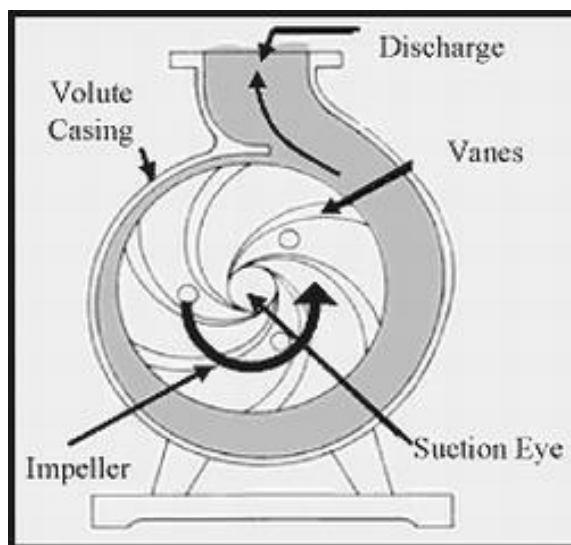

## **Conversion of Kinetic Energy to Pressure Energy**

The key idea is that the energy created by the centrifugal force is kinetic energy. The amount of energy given to the liquid is proportional to the velocity at the edge or vane tip of the impeller. The faster the impeller revolves or the bigger the impeller is, then the higher will be the velocity of the liquid at the vane tip and the greater the energy imparted to the liquid.

This kinetic energy of a liquid coming out of an impeller is harnessed by creating a resistance to the flow. The first resistance is created by the pump volute (casing) that catches the liquid and slows it down. In the discharge nozzle, the liquid further decelerates and its velocity is converted to pressure according to Bernoulli's principle.

Therefore, the head (pressure in terms of height of liquid) developed is approximately equal to the velocity energy at the periphery of the impeller

This head can also be calculated from the readings on the pressure gauges attached to the suction and discharge lines.

## **General Components of Centrifugal Pumps**

A centrifugal pump has two main components:

- I. A rotating component comprised of an impeller and a shaft
- II. A stationary component comprised of a casing, casing cover, and bearings.

## AIR CONDITIONING

An air conditioner is an appliance, system, or mechanism designed to extract heat from an area using a refrigeration cycle. In construction, a complete system of heating, ventilation, and air conditioning is referred to as HVAC. Its purpose, in the home or in the car, is to provide comfort during either hot or cold weather.

### Air conditioning system basics and theories

#### Refrigeration cycle

A simple diagram of the refrigeration cycle contains 1) condensing coil, 2) expansion valve, 3) evaporator coil, 4) compressor. In the refrigeration cycle, a heat pump transfers heat from a lower temperature heat source into a higher temperature heat sink. Heat would naturally flow in the opposite direction. This is the most common type of air conditioning. A refrigerator works in much the same way, as it pumps the heat out of the interior into the room in which it stands.

This cycle takes advantage of the way phase changes work, where latent heat is released at a constant temperature during a liquid/gas phase change, and where a different pressure of a pure substance means that it will condense/boil at a different temperature.

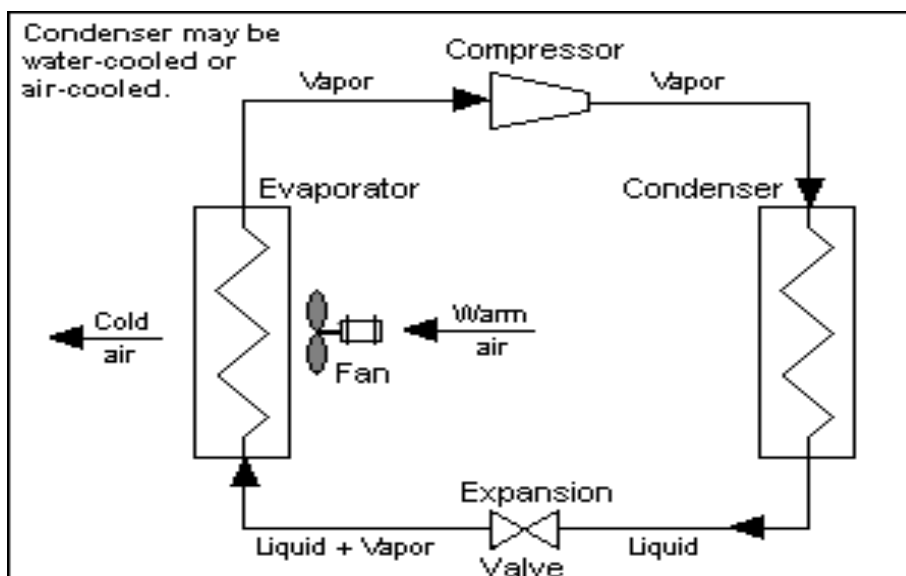

The most common refrigeration cycle uses an electric motor to drive a compressor. In an automobile, the compressor is driven by a belt over a pulley, the belt being driven by the engine's crankshaft (similar to the driving of the pulleys for the alternator, power steering, etc.). Whether in a car or the house, both use electric fan motors for air circulation. Since evaporation occurs when heat is absorbed, and condensation occurs when heat is released, air conditioners are designed to use a compressor to cause pressure changes between two compartments, and actively condense and pump a refrigerant around.

A refrigerant is pumped into the cooled compartment (the evaporator coil), where the low pressure and low temperature cause the refrigerant to evaporate into a vapor, taking heat with it. In the other compartment (the condenser), the refrigerant vapor is compressed and forced through another heat exchange coil, condensing into a liquid, rejecting the heat previously absorbed from the cooled space and the cycle repeats to keep the system at the required temperature.

## TOPIC BEYOND SYLLABUS

### MACHINING A WORKPIECE BY BORING AND INTERNAL THREAD CUTTING OPERATIONS USING LATHE

**Aim:**

To perform the boring and internal thread cutting operations on the given work piece as per the given dimensions.

**Material Required:**

- Mild steel rod

**Tools Required:**

- Lathe
- Steel rule
- Vernier caliper
- Cutting tool
- Scriber
- Chuck key
- Tool post key
- Internal thread cutting tool

**Procedure:**

1. The dimension of the given work piece are checked by vernier caliper.
2. The work piece is held in the lathe chuck properly and it is tightened by chuck key.
3. The cutting tool is set in a tool post such that the point of the cutting tool coincides with the lathe axis.
4. The machine is switched ON to remove the work piece at the selected speed.
5. By the giving cross feed and longitudinal feed to the cutting tool the facing and turning operations are done respectively.
6. The speed of the work piece is reduced.
7. The external thread cutting operation is done by using external V thread cutting tool by engaging thread cutting mechanism.
8. The work piece is removed from the chuck and all the dimensions are measured and checked.

## BORING AND INTERNAL THREAD CUTTING OPERATIONS

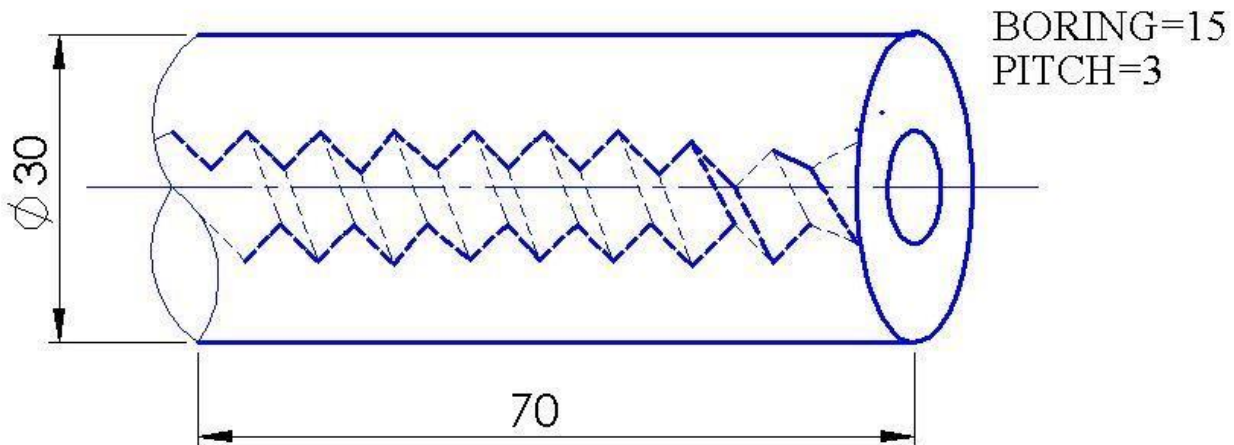

ALL DIMENSIONS ARE IN MM

### Calculate Time for Boring

$$\text{Time for Boring} = \frac{\text{Length to be bored}}{\text{Feed/Rev.} \times \text{r.p.m.}}$$

### Calculate Time for Threading

$$\text{Time for Threading} = \frac{\text{Length of Thread}}{\text{Pitch} \times \text{r.p.m.}}$$

Gearing ratio= Driver teeth/Driven teeth= TPI to be cut / TPI on lead screw (inch)

Gear ratio= Driver teeth/Driven teeth=  $5Pn/127$ (metric)

**Depth of cut** = 0.6403Xpitch

Pitch=1/No of TPI

Result: Thus the required size and shape of the given work piece is obtained

**Fusion welding.** Manual arc welding—one of the simplest welding methods—is based on the use of an electric arc. One pole of the power source is connected to a holder by means of a flexible cable; the other pole is connected to the object being welded. A carbon or metal electrode is inserted into the holder. If the electrode is touched briefly to the object, an arc is formed. The arc melts the base metal and the electrode rod (if the rod is made of metal), thus forming a molten pool, or weld puddle. Upon solidification, this pool becomes the weld. For a steel electrode, the temperature of the welding arc ranges from 6,000° to 10,000°C. Power supplied to the arc from specially designed units has a current of 100–350 amperes at 25–40 volts.

In arc welding, the oxygen and nitrogen of the atmosphere interact with the molten metal, forming oxides and nitrides that lower the strength and plasticity of the welded joint. There are internal and external methods of protecting the weld zone, such as introducing various substances into the electrode material or covering the electrodes (internal protection) or introducing inert gases or carbon dioxide into the weld zone or covering the weld zone with a flux (external protection). In the absence of external protection, the welding arc is called an unshielded arc; if external protection is used, it is called either a shielded arc or a submerged arc. Arc welding with an unshielded arc and consumable, covered electrodes is the most important method in actual practice. The high quality of the weld produced makes it possible to use this method for the fabrication of critical load-bearing parts.

One of the most important problems in welding engineering is the mechanization and automation of arc welding. Semiautomatic arc welding is often the most appropriate method for fabricating parts having complex shapes. In such a process, the feed of the electrode wire into the holder of a semiautomatic welder is mechanized. The arc may also be protected by a flux. The method, called submerged arc welding, was proposed in the late 19th century by N. G. Slavianov, who used powdered glass as a flux. An industrial version of the process was developed and introduced during the 1940's under the direction of Academician O. E. Paton. Submerged arc welding has found a substantial number of industrial applications because it is easily automated, is quite efficient, can be used in producing various types of welded joints, and yields a high-quality weld. During the welding process, the arc is covered by a layer of flux. The layer protects the operator's eyes from radiation, but it also makes it difficult to observe the formation of the weld.

Mechanized welding methods make use of gas-shielded arc welding, a technique introduced by N. N. Benardos at the end of the 19th century. The welding is done with a welding torch or in gas-filled chambers. Gases are fed to the arc continuously, thus ensuring a high-quality joint. Both inert and active gases can be used; the best results are obtained using helium or argon. Helium is only used for special, critical work because of its high cost. A more widely used technique is automatic or semiautomatic welding with no consumable tungsten electrodes or consumable steel electrodes in argon or a mixture of argon with other gases. This method is appropriate for joining parts that usually are comparatively thin and that are made of aluminum, magnesium, or their alloys, all types of steel, high-temperature alloys, titanium and its alloys, nickel and copper alloys, niobium, zirconium, tantalum, and some other metals. Carbon dioxide welding is a very economical method that produces high-quality welds. Industrial applications of this technique were developed in the 1950's by the Central Scientific Research Institute of Technology and Machine Building under the direction of K. V. Liubavskii. The method uses an electrode wire and is suitable for joining steel parts 1–30 mm thick.