



5104-ARUNAI ENGINEERING COLLEGE
TIRUVANNAMALAI



DEPARTMENT OF MECHANICAL

ME 8513 -METROLOGY AND MEASUREMENTS
LABORATORY

LAB MANUAL

ME 8513 METROLOGY AND MEASUREMENTS LABORATORY

EX NO	DATE	INDEX	MARK	SIGN
1.a		CALIBRATION OF a) VERNIER CALIPER		
1.b		b) MICROMETER		
1.c		c) DIAL GAUGE		
2.a		CHECKING DIMENSIONS OF PART USING SLIP GAUGES a) VERNIER HEIGHT GAUGE		
2.b		b) VERNIER DEPTH GAUGE		
3.		MEASUREMENTS OF GEAR TOOTH DIMENSIONS		
4.a		MEASUREMENTS ANGLE USING a) SINE BAR		
4.b		b) SINE CENTER		
4.c		c) BEVEL PROTRACTOR		
4.d		d) TOOL MAKERS MICROSCOPE		
5.		MEASUREMENTS OF STRAIGHTNESS & FLATNESS		
6.a		MEASUREMENTS OF THREAD PARAMETERS a) PROFILE PROJECTOR		
6.b		b) FLOATING CARRIAGE MICROMETER		
7.a		SETTING UP OF COMPARATORS FOR INSPECTION a) PNEUMATIC COMPARATOR		
7.b		b) MECHANICAL COMPARATOR		

ME 8513 METROLOGY AND MEASUREMENTS LABORATORY

EX NO	DATE	INDEX	MARK	SIGN
8.		MEASUREMENT OF TEMPERATURE USING THERMOCOUPLE TRAINER		
9.		MEASUREMENT OF FORCE USING LOAD CELL		
10.		MEASUREMENT OF TORQUE USING TORQUE MEASURING SETUP		
11.		BORE DIAMETER MEASUREMENT USING TELESCOPIC GAUGE		
12.		BORE GAUGE		
13.		SURFACE FINISH MEASURING EQUIPMENT		

ME 8513 METROLOGY AND MEASUREMENTS LABORATORY

OBJECTIVES:

To familiar with different measurement equipments and use of this industry for quality inspection

LIST OF EXPERIMENTS:

1. Tool Maker's Microscope
2. Comparator
3. Sine Bar
4. Gear Tooth Vernier Caliper
5. Floating gauge Micrometer
6. Co ordinate Measuring Machine
7. Surface Finish Measuring Equipment
8. Vernier Height Gauge
9. Bore diameter measurement using telescope gauge
10. Bore diameter measurement using micrometer
11. Force Measurement
12. Torque Measurement
13. Temperature measurement
14. Autocollimator

TOTAL: 45 PERIODS

OUTCOMES

Ability to handle different measurement tools and perform measurements in quality impulsion

*Ex. No: 1a**Date:*

CALIBRATION OF (Vernier Caliper / Micrometer / Dial Gauge)

AIM

To study and calibrate the Vernier caliper, Micrometer, and Dial gauge.

APPARATUS REQUIRED

- Surface plate
- Vernier caliper
- Micrometer
- Dial gauge
- Slip gauges

SPECIFICATION

- | | | |
|-------------------|-------------------|----------------|
| ➤ Vernier caliper | Range: 0-300 'mm' | L. C:0.02 'mm' |
| ➤ Micrometer | Range: 0-25 'mm' | L. C:0.01 'mm' |
| ➤ Dial gauge | Range: 0-10 'mm' | L. C:0.01 'mm' |

STUDY**1. Vernier Caliper**

The Vernier caliper has one 'L' shaped frame with a fixed jaw on which Vernier scale is attached. The principle of Vernier is that when two scale divisions slightly different in sizes can be used to measure the length very accurately.

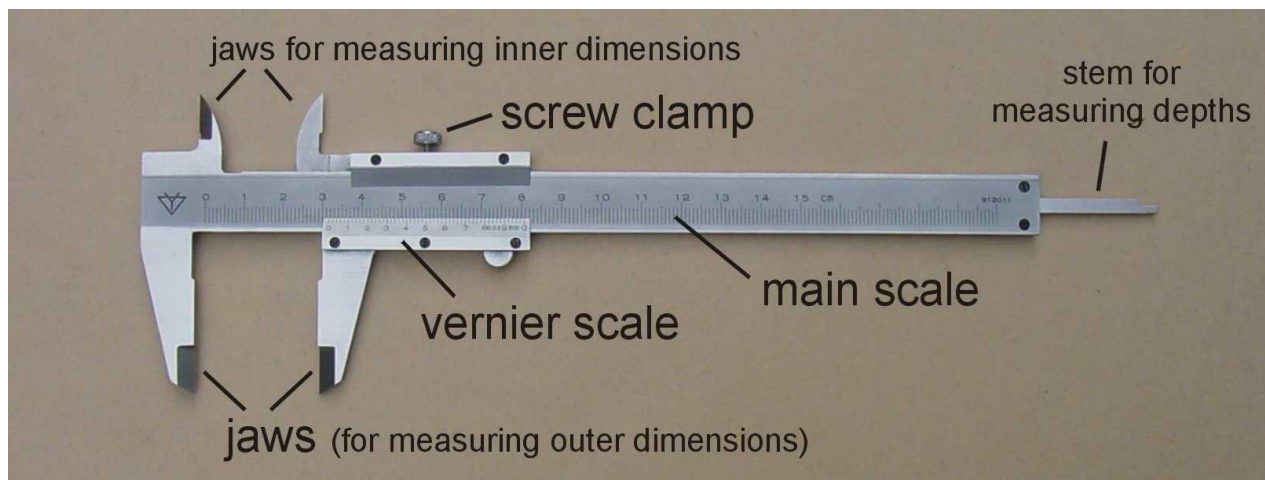

Fig: VERNIER CALIPER

Least Count is the smallest length that can be measured accurately and is equal to the difference between a main scale division and a Vernier scale division.

$$\text{LEAST COUNT} = 1 \text{ Main scale division} - 1 \text{ Vernier scale division}$$

Uses:

- It is used to measure the external diameter, the internal diameter and the length of the given specimen.

2. Micrometer

The micrometer has an accurate screw having about 10 to 20 threads/cm and revolves in a fixed nut. The end of the screw is one tip and the other is constructed by a stationary anvil.

$$\text{LEAST COUNT} = \text{Pitch scale division} / \text{Number of threads}$$

$$\text{Pitch scale division} = \text{Distance moved} / \text{number of rotation}$$

Uses:

- Outside micrometer is used to measure the diameter of solid cylinder.
- Inside micrometer is used to measure the internal diameters of hollow cylinders and spheres.

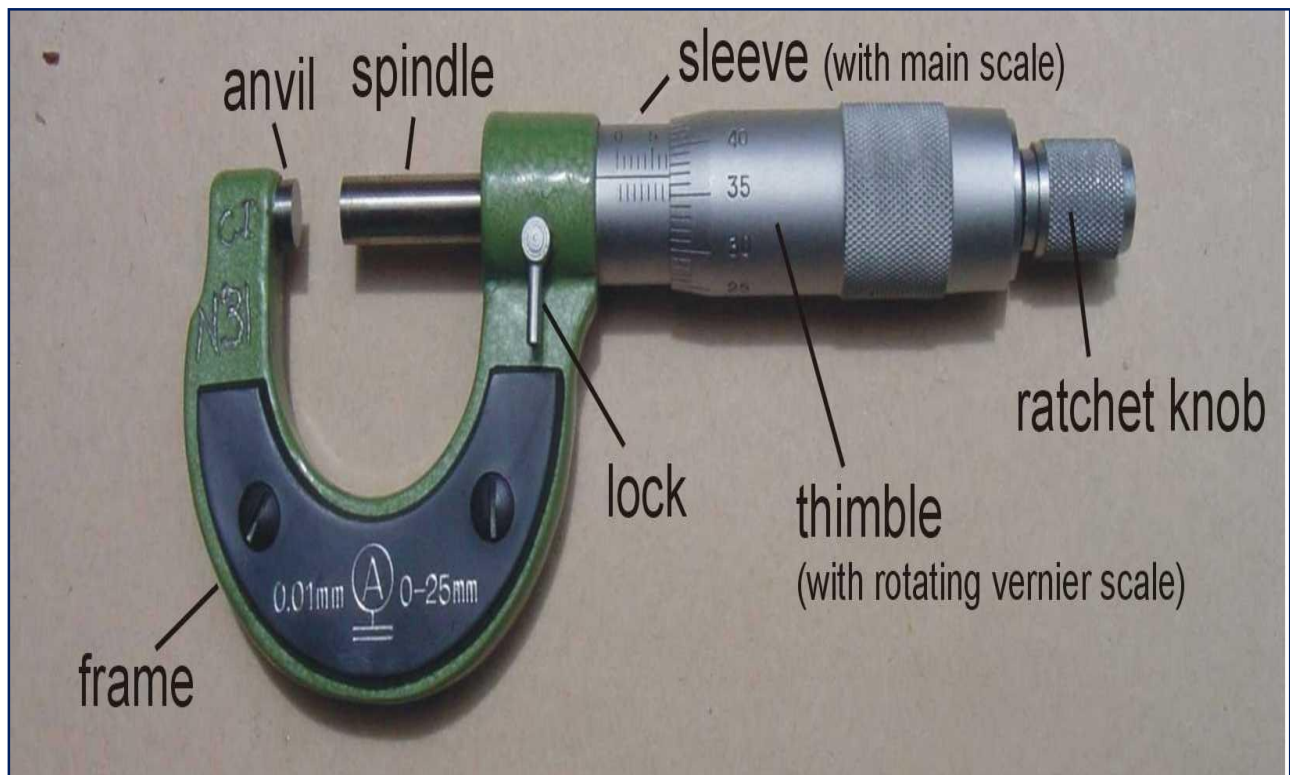

Fig: MICROMETER

3. Dial gauge

The dial gauge has got 2 hands. The short hand reads in mm. One complete revolution of long hand reads one mm. The plunger of the dial gauge has to be placed on the surface whose dimension has to be read.

Least Count = One division of the circular scale with long hand.

Uses:

It is used as a mechanical comparator.

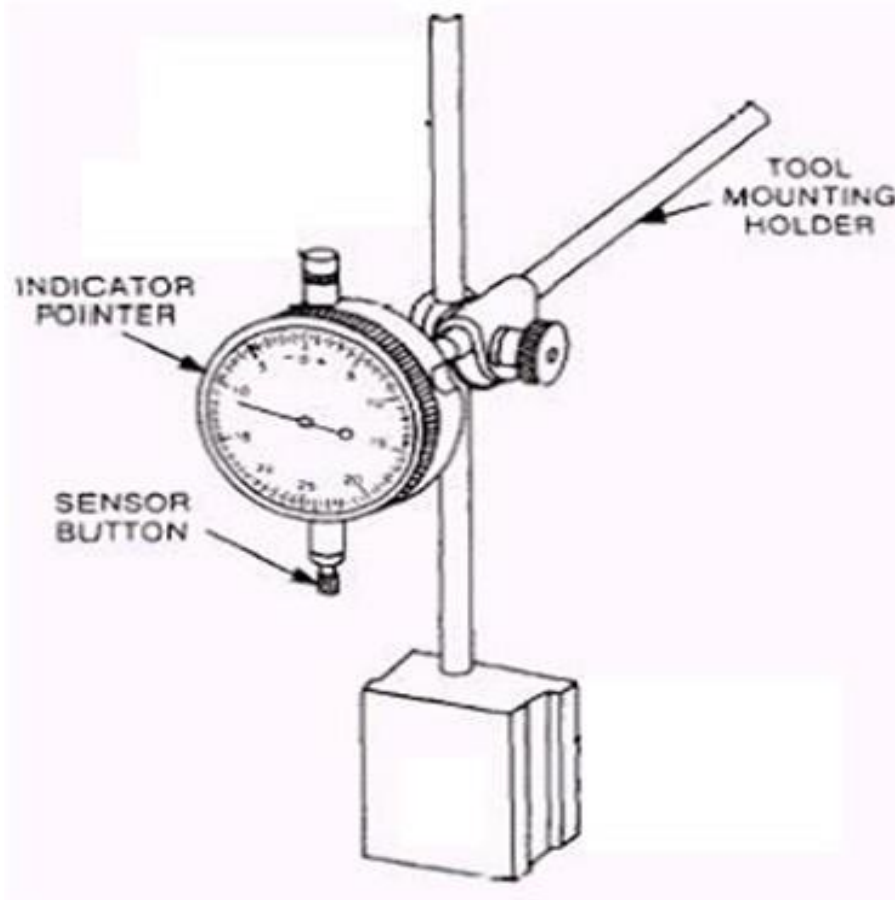

Fig: DIAL GAUGE

4. Slip gauges

They are rectangular blocks hardened and carefully stabilized. The surfaces are highly polished to enhance wringing. It is used as a reference standard for transferring the dimensions of unit of length from primary standard. It is generally made up of high carbon, high chromium hardened steel.

Uses:

- These are accurate and used as comparator.

5. **Surface plate**

The foundation of all geometric accuracy and indeed of all dimensional measurement in workshop is surface plate. It is a flat smooth surface sometimes with leveling screws at the bottom.

Uses:

- It is used as a base in all measurements

Procedure for Calibration:

1. The range of the instruments is noted down.
2. Within that range, slip gauges are selected.
3. The measuring instrument is placed on the surface plate and set for zero and the slip gauges are placed one by one between the measuring points (jaws of the instruments.)
4. The slip gauge (actual) readings and the corresponding (observed) readings in the measuring instruments are noted down and tabulated.

FORMULA USED:

1) $MD = [MSR + (VSC \times LC)]$

- MD-Measured Dimension
- MSR-Main Scale Reading
- VSC-Vernier Scale Coincide
- LC-Least Count

2) $ERROR = \text{Slip gauge reading} - \text{Measured Dimension}$

ME 8513 METROLOGY AND MEASUREMENTS LABORATORY

TABULATION (Vernier Caliper Using Slip Gauge)

S.NO	Least Count of vernier = 0.02mm					Error
	Slip gauge reading 'mm'	Vernier Caliper Reading 'mm'				
		MSR	VSC	VSR = VSC X LC	MD = MSR + VSR	
1						
2						
3						
4						
5						
6						
7						
8						
9						
10						

ME 8513 METROLOGY AND MEASUREMENTS LABORATORY

TABULATION (Micrometer using Slip gauge)

Least Count of micrometer = 0.01mm						
Sl. No	Slip gauge reading 'mm'	Main scale Reading (MSR) in 'mm'	Thimble scale division (TSD) 'mm'	Thimble scale reading (TSR) = TSD X Least count in 'mm'	Measure dimension (MD) in 'mm'	Error
1						
2						
3						
4						
5						
6						
7						
8						
9						
10						

ME 8513 METROLOGY AND MEASUREMENTS LABORATORY

TABULATION (Dial Gauge using Slip gauge)

Least Count of dial gauge= 0.01mm				
Sl.no	Slip gauge reading (mm)	Dial gauge reading (mm)		Error
		Initial valve in (mm)	Final valve in (mm)	
1				
2				
3				
4				
5				

CACULATION:

GRAPHS

- ❖ Slip gauges reading Vs Measured Dimension
- ❖ Slip gauge reading Vs Error

Result:

The precision measuring instruments are studied and calibrated.

Ex. No: 2a

Date:

VERNIER HEIGHT GAUGE

AIM

To determine the height of the given specimen by using Vernier Height gauge.

APPARATUS REQUIRED

- Vernier Height gauge,
- Work piece,
- Surface plate.

PROCEDURE

1. Clean the main scale, Vernier scale and measuring jaws of the Vernier Height gauge
2. The vernier height gauge is checked for zero error
3. Place the job in Surface plate.
4. Place the measuring jaw such that it touches the surface to be measured from the Smooth surface
5. Measure the main scale reading and Vernier scale coincidence of the Vernier Height gauge

FORMULA

$$MD = [MSR + (VSC \times LC)]$$

- MD-Measured Dimension
- MSR-Main Scale Reading
- VSC-Vernier Scale Coincide
- LC-Least Count

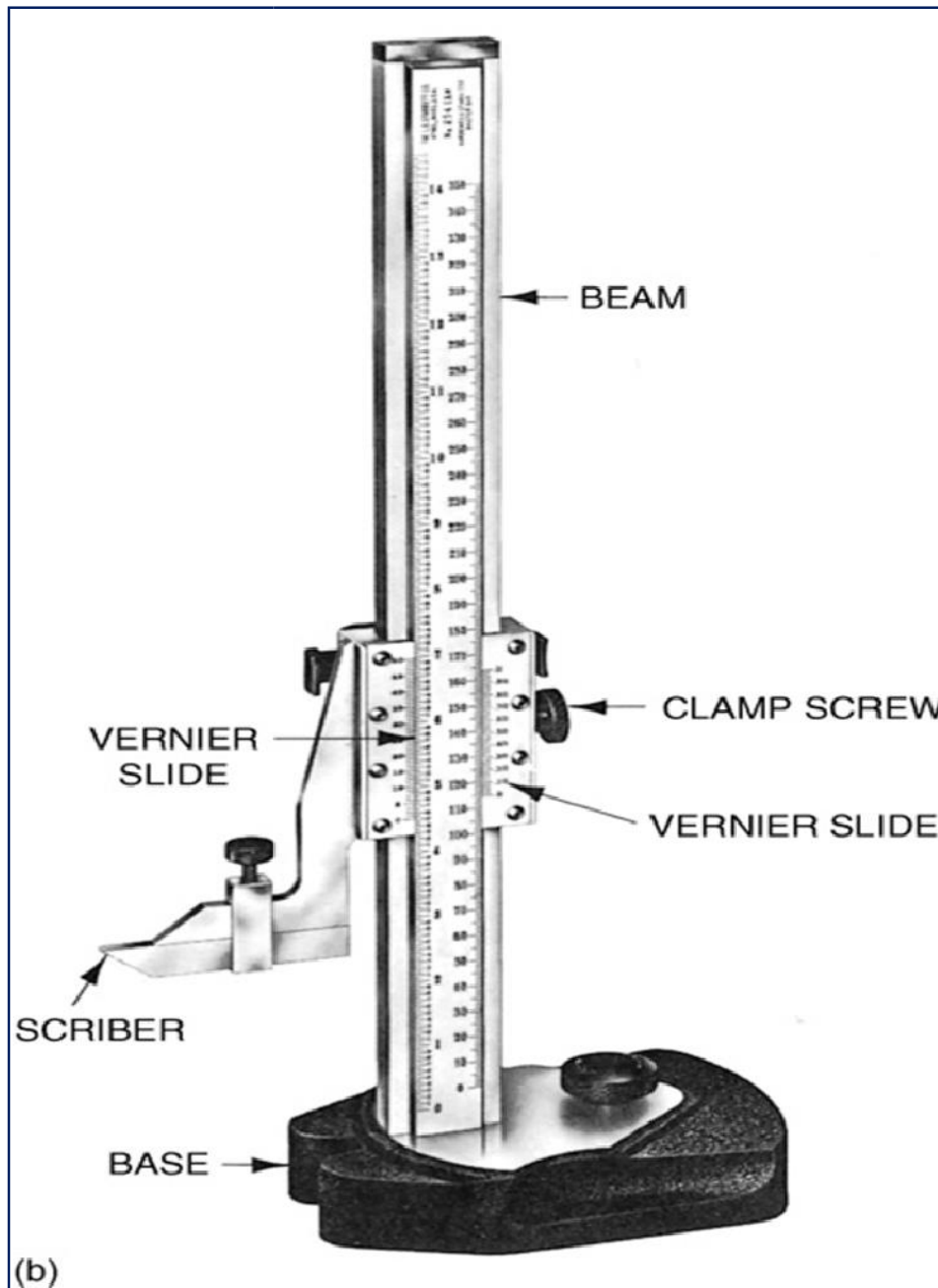

Fig: VERNIER HEIGHT GAUGE

TABULATION (Vernier Height Gauge)

Least count = 0.02mm					
S.NO	Specimen Details	Main scale reading (MSR) (mm)	Vernier Scale coincidence (VSC) (mm)	Vernier scale reading (VSR) = VSC X LC (mm)	Measured Dimension= (MD) in (mm)
1					
2					
3					
4					
5					

CALCULATION

Graph

- ❖ Main scale reading Vs Measured Dimension

RESULT

Thus the height of the given Specimen is determined using vernier height gauge.

Ex. No:2b

Date:

VERNIER DEPTH GAUGE

AIM

To determine the Depth of the given specimen to accuracy using Vernier Depth gauge

APPARATUS REQUIRED

- Vernier depth gauge
- Surface plate
- Work piece

PROCEDURE

1. The depth gauge is checked for Zero error
2. It is placed on the surface Plate
3. Thus the given specimen is placed on the surface plate
4. The work piece is placed inside the measuring jaw of the instrument
5. The main scale reading and vernier scale reading are noted
6. The readings are tabulated.

FORMULA USED

$$MD = [MSR + (VSC \times LC)]$$

- MD-Measured Dimension
- MSR-Main Scale Reading
- VSC-Vernier Scale Coincide
- LC-Least Count

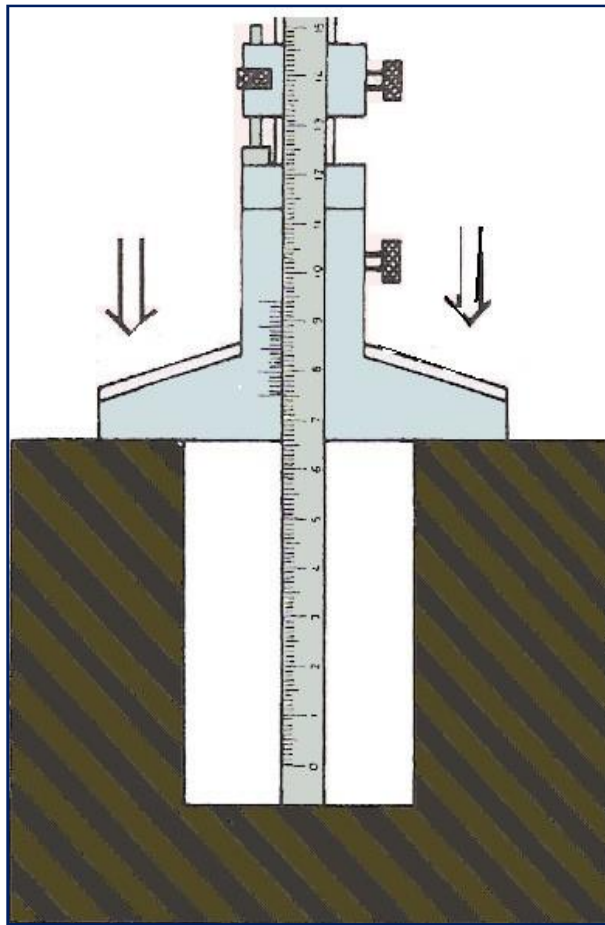

Fig: Vernier Depth Gauge

TABULATION (Vernier Depth Gauge)

Least count = 0.02mm					
S. No	Specimen Details	Main scale reading (MSR) (mm)	Vernier Scale coincidence (VSC) (mm)	Vernier scale reading (VSR) VSC X LC (mm)	Measured Dimension = MSR + VSR (mm)
1					
2					
3					
4					
5					

CALCULATION

Graph

- ❖ Main scale reading Vs Measured Dimension

RESULT

Thus the Depth of the given Specimen is determined using vernier depth gauge.

*Ex. No: 3**Date:*

MEASUREMENT OF GEAR PARAMETERS USING GEAR TOOTH VERNIER

AIM

To measure gear parameter by gear tooth Vernier.

APPARATUS REQUIRED

Gear tooth Vernier, Gear specimen,(SPUR GEAR),Vernier Caliper.

SPECIFICATION

Gear tooth Vernier Range = Horizontal = 0-40 mm

Vertical = 0-20 mm

L.C = 0.02 mm

FORMULA

1.	W	=	$NM \sin (90/N)$
2.	d	=	$NM \frac{1 + 2/N - \cos(90/N)}{2}$
3.	m	=	$\frac{D}{(N+2)}$
4.	% ERROR	=	$(W_s - W) / (W_s)$

Where ,

W = Chordal width of tooth in mm

D = Chordal addendum of gear in mm

M = Module of gear in mm

N = No. of teeth

D = outside Dia in gear in mm

W_s = Standard chordal thickness mm

W = chordal thickness mm

PROCEDURE

1. The N, D of the given gear block are measured.
2. The module m' is then calculated.
3. Theoretical values of 'W' and 'd' are computed.
4. Theoretical values of 'W' is set in horizontal Vernier scale of gear tooth Vernier and corresponding actual value scale.
5. Theoretical values of 'c' is set and 'W' is measured along
6. Horizontal scale.
7. This procedure is repeated for 5 teeth and value tabulated.

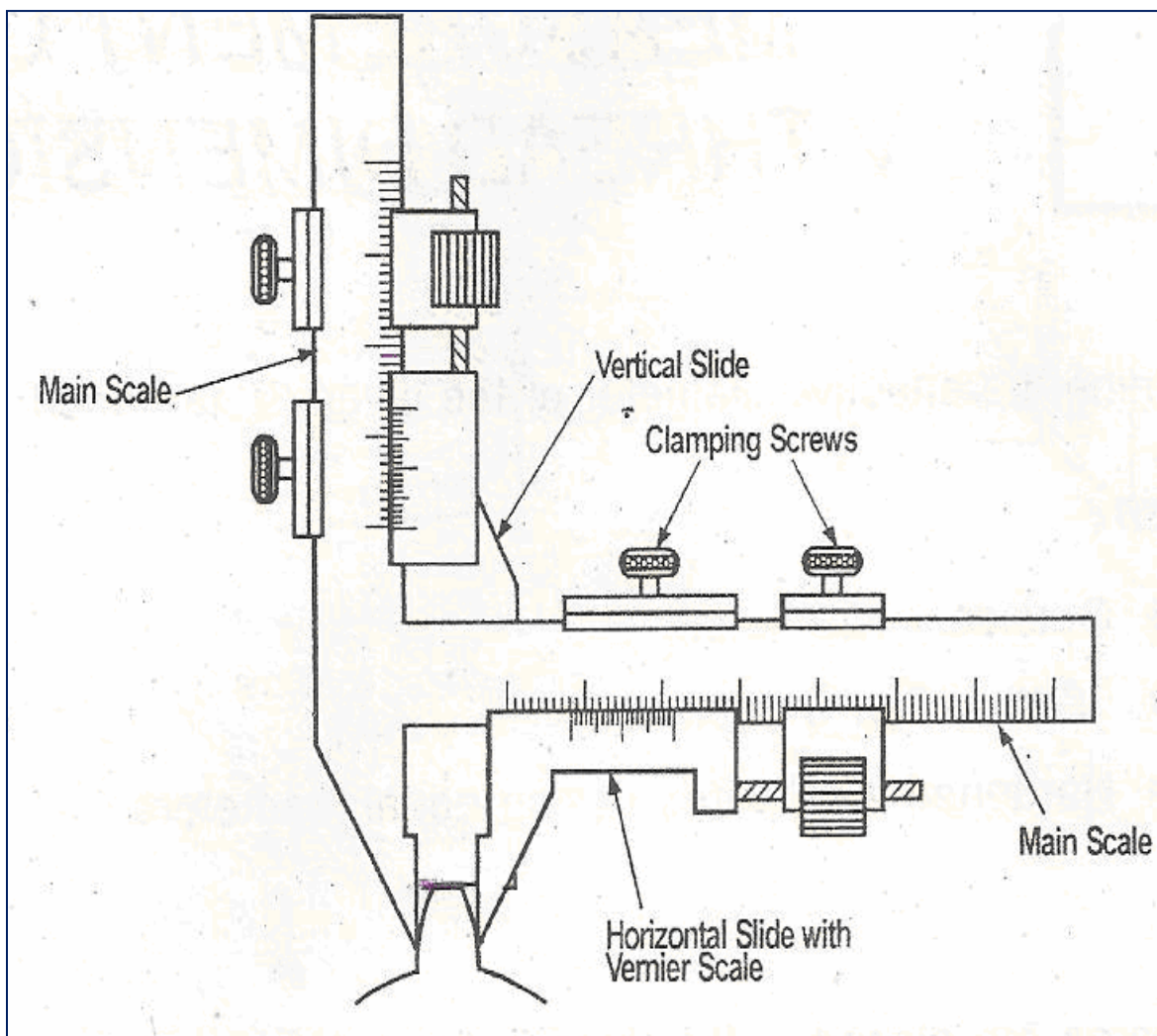

Fig: GEAR TOOTH VERNIER

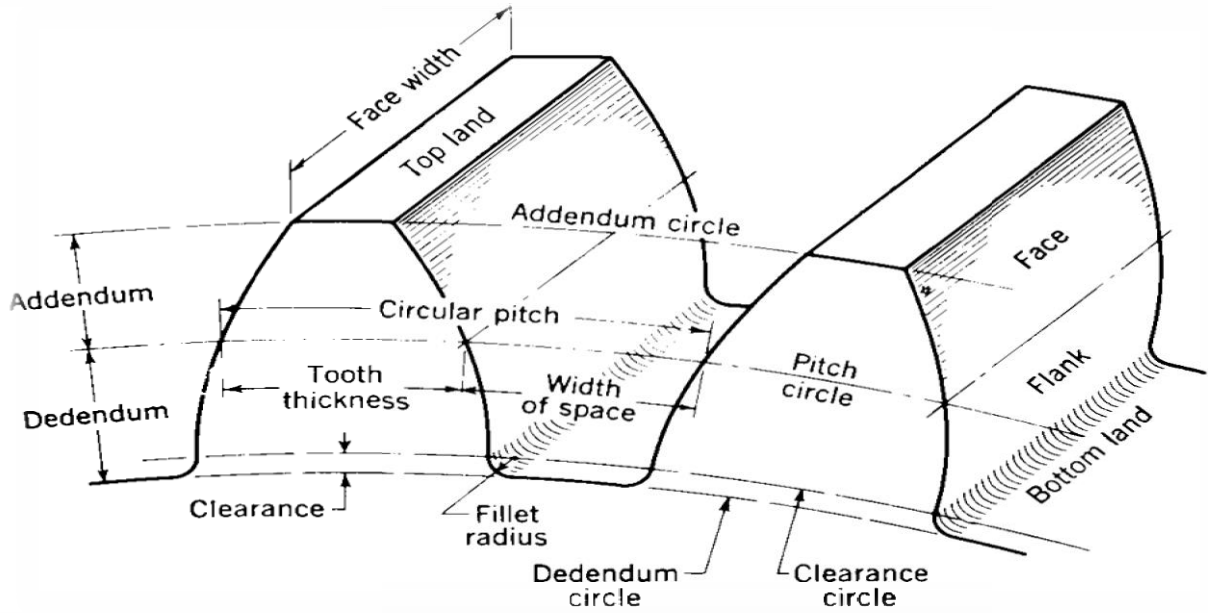

Fig: NOMENCLATURE OF GEAR

OUTSIDE DIAMETER OF GEAR

TRIAL	OUT SIDE DIAMETER 'D' mm	
	GEAR 1	GEAR 2
1		
2		
3		
4		
5		
AVERAGE		

TABULATION

SL. NO	SPECIMEN	NO. OF TEETH (N)	OUTER DIAMETER (OD) "mm"	CHORDAL Depth d "mm"	CHORDAL THICKNESS (W) "mm"				STANDARD CHORDAL THICKNESS Ws "mm"	ERROR(%) $= \frac{W_s - W}{W_s}$
					T1	T2	T3	AVG		
1	GEAR 1									
2	GEAR 2									

CALCULATION

RESULT

Thus the chordal thickness and addendum of gear is measured using gear tooth Vernier.

Ex. No: 4a

Date:

ANGULAR MEASUREMENT USING SINE BAR

AIM

To measure the taper angle of the given specimen using sine bar method.

APPARATUS REQUIRED:

- ❖ Sine bar
- ❖ Work Piece
- ❖ Surface plate
- ❖ Dial gauge with stand

FORMULA:

$$\sin \theta = \frac{H}{L}$$

Where,

H - Height of the slip gauge

L - Distance between the centers

θ - Inclined angle of the specimen

PROCEDURE

1. The given component is placed on the surface plate.
2. One roller of sine bar is placed on surface plate and bottom surface of sine bar is seated on the taper surface of the component.
3. The combination of slip gauges is inserted between the second roller of sine bar and the surface plate.
4. The angle of the component is then calculated by the formula given above.

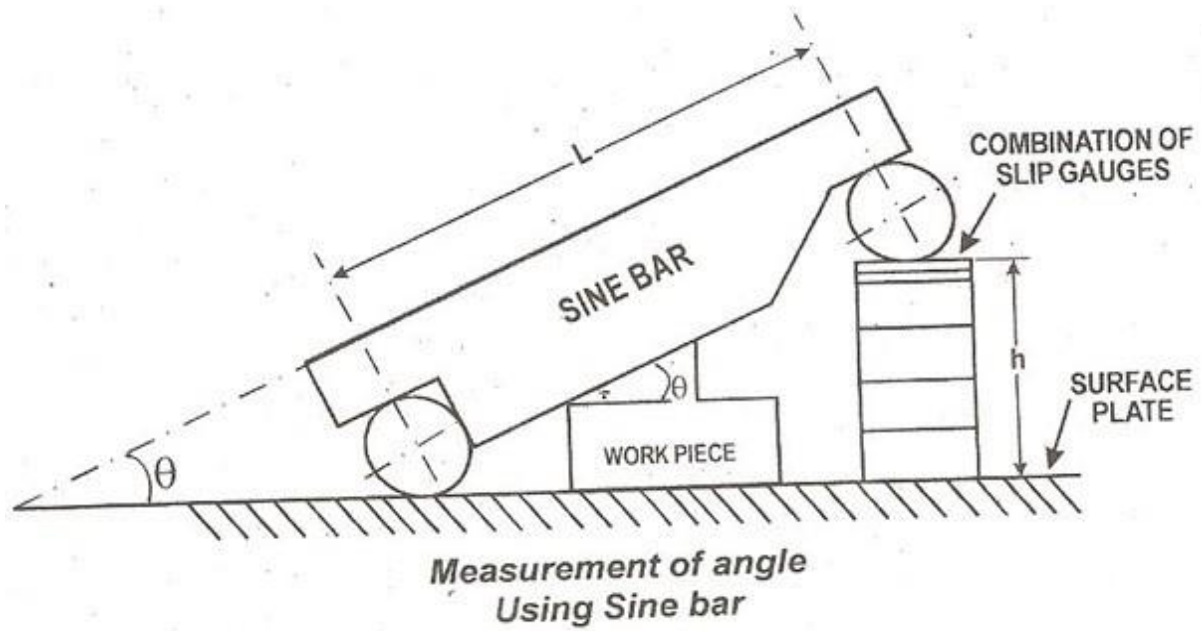

TABULATION (Sine Bar)

S. No	Length of the sine bar (L) "mm"	Height of the combination of slip gauge (H) "mm"	Taper Angle (θ) in 'degree'
1			
2			

CALCULATION

RESULT

Thus the angle in the work pieces were Determined using Sine bar

- ❖ Angle measured in work piece ,1 =----- 'degree'
- ❖ Angle measured in work piece ,2 =----- 'degree'

*Ex. No: 4b**Date:***ANGULAR MEASUREMENT USING SINE CENTER****AIM**

To measure the taper angle of the given specimen using sine center method.

APPARATUS REQUIRED

- Sine Center
- Slip gauge
- work piece

FORMULA USED

$$\sin \alpha = \frac{h}{L}$$

PROCEDURE

1. Clean the surface plate, Sine Center and Slip gauges using fine cotton cloth.
2. Place the Job in the smooth flat surface.
3. Place the sine bar in such a manner that the Lower surface of the Sine bar.
4. Was uniformly touches the surface whose angle to be measured.
5. Calculate the angle using the Formula

$$\sin \alpha = \frac{h}{L}$$

Where,

h - Vertical height of the slip gauge

L - Length of the sine Center

TABULATION

S. No	Length of the sine center (L) “mm”	Height of the combination of slip gauge (h) “mm”	Taper Angle (α) in ‘degree’
1			
2			

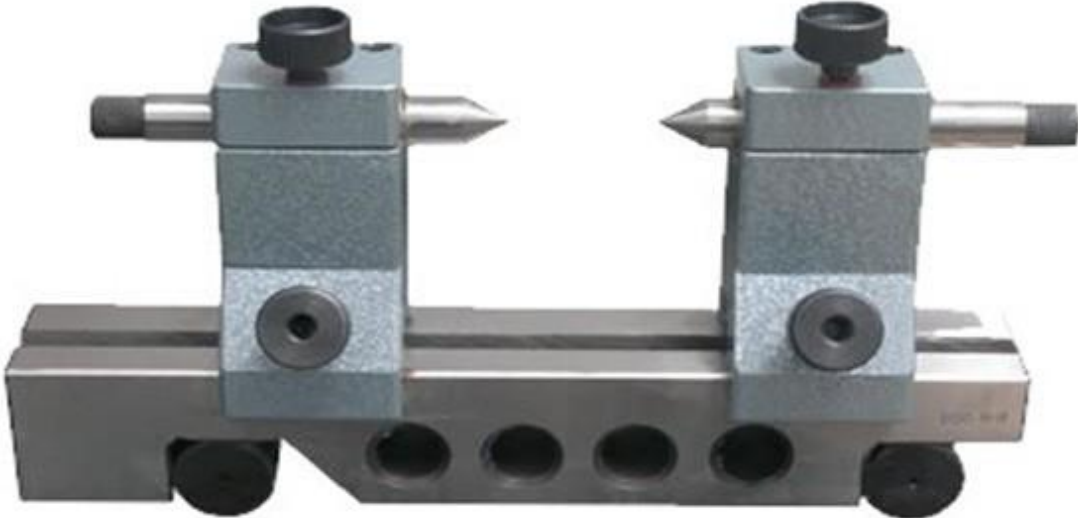

Fig: SINE CENTER

CALCULATION

RESULT

Thus the angle in the work pieces was determined using Sine center.

- ❖ Angle measured in work piece, 1 = ----- ‘degree’
- ❖ Angle measured in work piece, 2 = ----- ‘degree’

ANGULAR MEASUREMENT USING BEVEL PROTRACTOR

AIM

To measure the angle in the given work piece using Bevel Protractor.

APPARATUS REQUIRED

- Work piece
- Bevel Protractor

PROCEDURE

1. Clean the Bevel protractor with the fine cotton cloth.
2. The work piece whose angle to be measured is placed between the stock and the blade.
3. Note down the main scale reading and Vernier scale coincidence.
4. Tabulate the readings.

FORMULA

$$\begin{aligned}\text{Leastcount} &= \frac{\text{one main scale division}}{\text{No. of division on vernier scale}} \\ &= \frac{1^\circ}{12} \times 60 \\ &= 5 \text{ mins}\end{aligned}$$



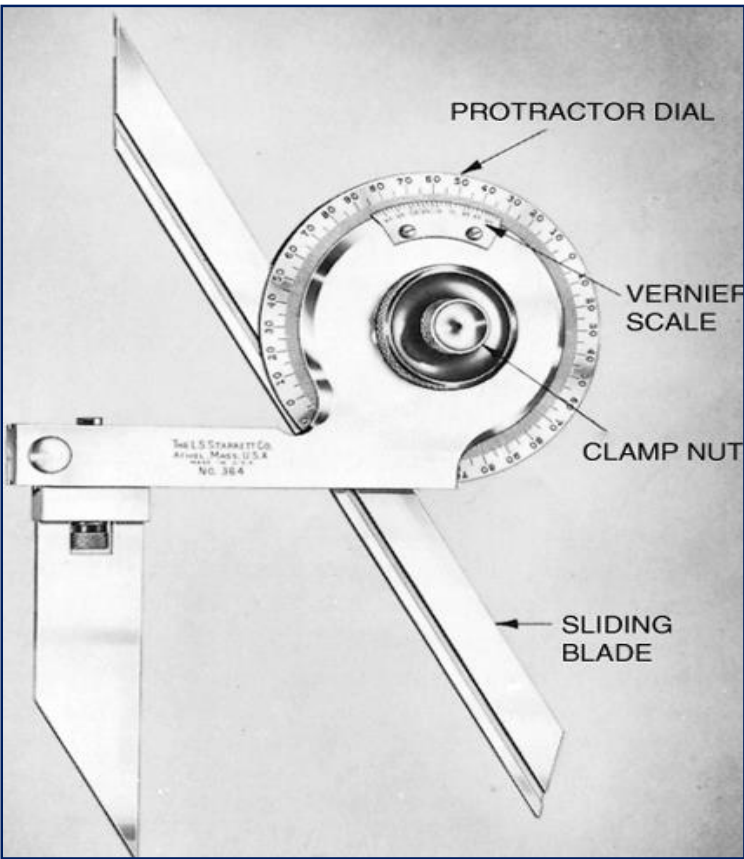

Fig: BEVEL PROTRACTOR

ME 8513 METROLOGY AND MEASUREMENTS LABORATORY

TABULATION (Work Piece 1)

S.NO	Least count = 5 mins			
	Main scale reading (MSR) 'deg'	Vernier scale coincidence (VSC) 'div'	Vernier Scale reading (VSC X LC) 'mins'	Total reading = (MSR + VSR) 'deg'
1				
2				
3				
4				
5				
AVERAGE				

ME 8513 METROLOGY AND MEASUREMENTS LABORATORY

TABULATION (Work Piece 2)

S.NO	Least count = 5 mins			
	Main scale reading (MSR) 'deg'	Vernier scale coincidence (VSC) 'div'	Vernier Scale reading (VSC X LC) 'mins'	Total reading = (MSR + VSR) 'deg'
1				
2				
3				
4				
5				
AVERAGE				

RESULT

The angle of the given work piece was measured using Bevel protractor

- ❖ Angle of the given work piece1 =-----‘degree’
- ❖ Angle of the given work piece2 =-----‘degree’

Ex. No:4d

Date:

ANGULAR MEASUREMENT USING TOOL MAKERS MICROSCOPE

AIM

To measure the cutting tool parameters of single point cutting tool & screw thread parameters using tool makers microscope.

APPARATUS REQUIRED

- Tool maker's microscope
- Work piece
 - ❖ Single point cutting tool
 - ❖ Screw thread

PROCEDURE

1. Switch on the main.
2. Switch on the microscope lights.
3. Select the capacity of the lens for precision operation.
4. Place the object on the glass table to get the clear image rotate the wheel provided at the light side.
5. After getting the clear image, locate the crosswire at the initial point on the image.
6. Now note down the micrometer reading.
7. Move the cross wire from initial point to the final point on the image, which is to be measured.
8. Note down the micrometer reading, this operation is done by using micrometer.
9. Now the difference between the initial and the final reading i.e. distance traveled object.

ME 8513 METROLOGY AND MEASUREMENTS LABORATORY

TABULATION (Single Point cutting Tool)

S. No	Single Point cutting Tool Angle	Initial Reading 'deg'	Final Reading 'deg'	Actual Reading 'deg'
1	End cutting edge angle			
2	side cutting edge angle			
3	End relief angle			

ME 8513 METROLOGY AND MEASUREMENTS LABORATORY

TABULATION (Thread Parameters)

S. No	Initial angle 'degree'	Final angle 'degree'	Difference 'degree'	Average 'degree'
1				
2				

TABULATION

S. No	Dimension to be measured	Initial point 'mm'	Final point 'mm'	Difference 'mm'
1	Pitch			
2	Depth			
3	Major Diameter			
4	Minor Diameter			

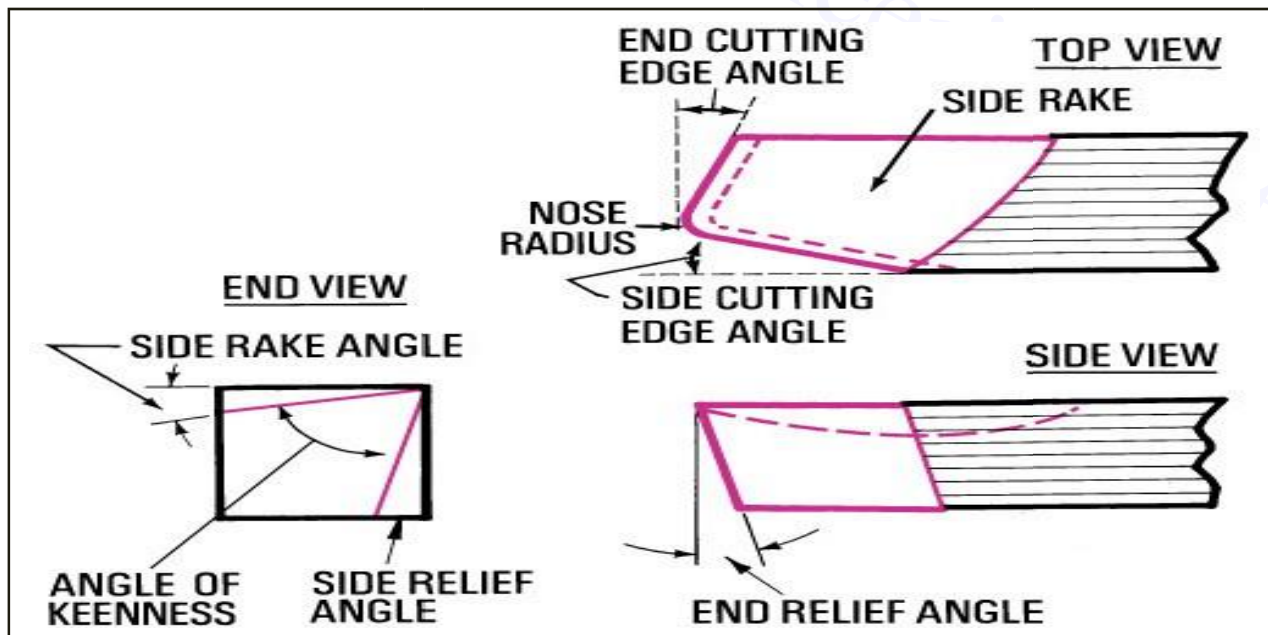
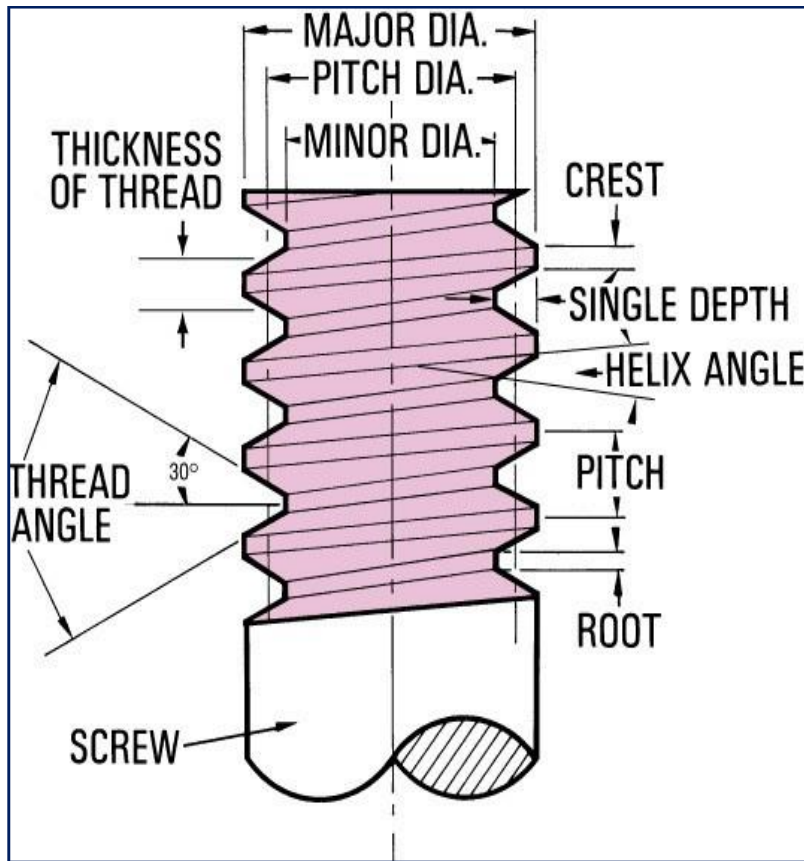

Fig: Cutting Tool



RESULT

1. The angle of the given work piece was measured using Tool makers microscope.

- ❖ Angle 1 =
- ❖ Angle 2 =
- ❖ Angle 3 =

2. Thus the thread parameters of given screw thread was found using Tool makers microscope.

- ❖ Major diameter of the screw thread = 'mm'
- ❖ Minor diameter of the screw thread = 'mm'
- ❖ Pitch of screw thread = 'mm'
- ❖ Depth of screw thread = 'mm'
- ❖ Angle of screw thread = 'degree'

Ex. No: 5

Date:

MEASUREMENT OF STRAIGHTNESS AND FLATNESS USING AUTOCOLLIMATOR

AIM

Measurement of the Straightness and flatness Using Autocollimator

APPARATUS

- Autocollimator
- Straight edge

FORMULA

Interval Length = L

$$L = (\theta/60 \times \pi/180) \times F$$

L = Interval Length (mm)

F = Focal Length (mm)

PROCEDURE

1. Make the distance of 50mm internal on the w/p
2. Set the cross wire so that two cross will coincide.
3. Set the mirror so that the cross wire will be visible
4. Move the reflector on next 50mm mark and adjust it to see reflection of crosswire.
5. Take the reading of reflected crosswire deviated or moved up or down. Measure the distance between two crosswire.

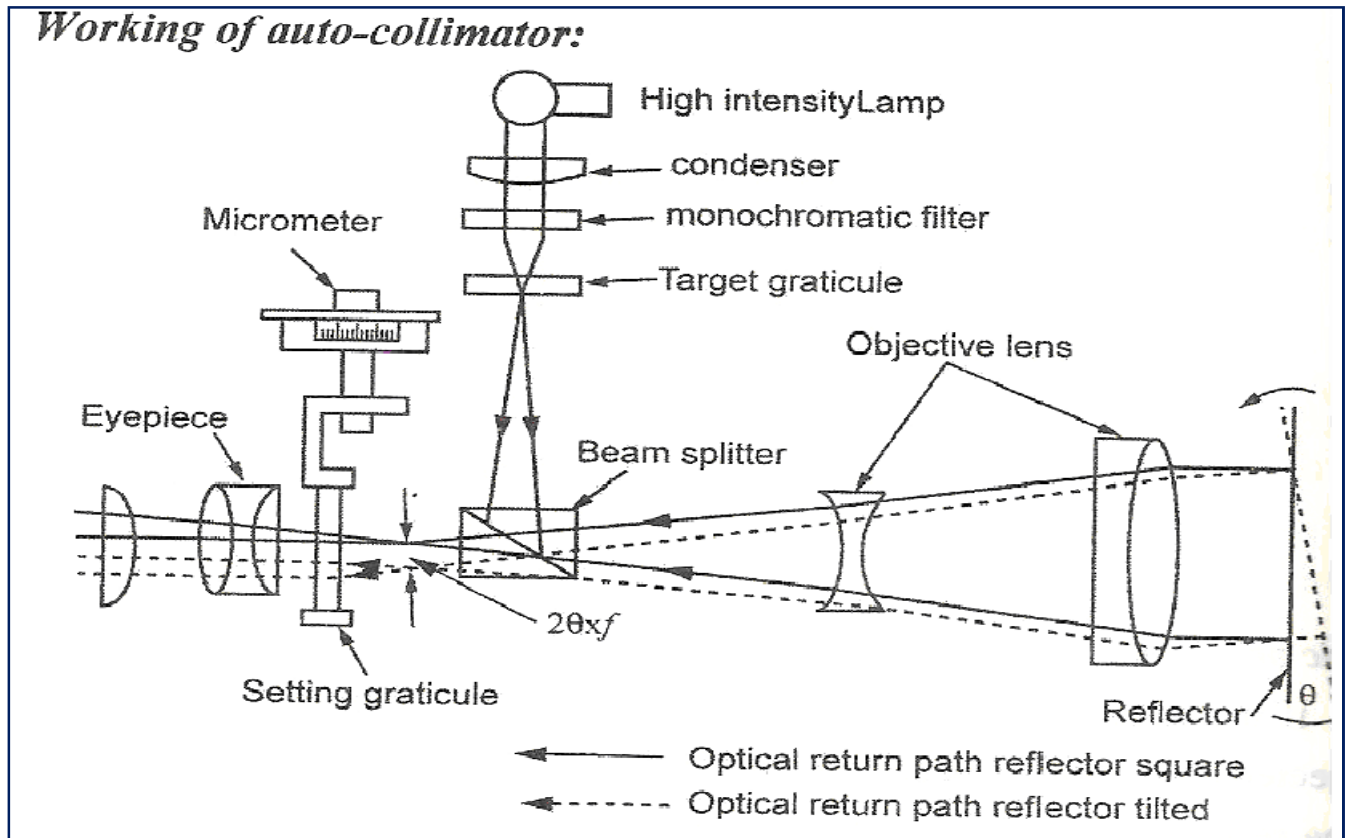

CALCULATION:



TABULATION

Position (1)	Mean Reading Of Auto Collimator	Difference From First Reading	Rise (Or) Fall Interval Length 'L' (mm)	Cumulative Rise (Or) Fall (mm)	Adjustment To Bring Both Ends To Zero (mm)	Errors From Straight Line (mm)
o – a						
a – b						
b – c						
c – d						

Graph

- ❖ Interval length Vs cumulative raise (or) fall

RESULT

Thus Straightness and flatness of the given specimen is measured Using Autocollimator.

Ex. No: 6a

Date:

MEASUREMENT OF THREAD PARAMETERS USING PROFILE PROJECTOR

AIM

To measure the thread parameter of given screw thread using Profile projector

APPARATUS REQUIRED

- Profile projector
- Specimen

PARAMETER TO BE MEASURED

- Major and Minor diameter
- Depth and Pitch of thread
- Addendum and dedendum.

THEORY

Minor diameter

It is the diameter of an Imaginary co-axial cylinder which would touch the root of external or internal thread.

Major Diameter

It is the diameter of an imaginary co-axial cylinder which would touch the crest of external or internal thread.

Depth

The distance between the crest and root of the thread is called Depth of Thread

Pitch of Thread

The distance measured parallel to the axis from a point on a thread to the Corresponding next point

Addendum

For external thread it is the radial distance between major and pitch cylinders.

Dedendum

For external thread it is the radial distance between the Pitch and Minor cylinders

For internal thread it is the radial distance between major and Pitch cylinders

Helix angle

The helix angle is made by the thread at the pitch line with axis

PROCEDURE

1. Clean the instrument and its accessories by fine cotton cloth
2. Clamp the specimen in between the jaws present in the profile Projector
3. Switch on the power and adjust the degree of magnification in profile projector
4. The magnification depends upon the distance between the Local plane of the lens and the screen
5. Bring the specimen image to the screens axis by adjusting the micrometer and rotation of screen
6. Now the parameters of threads are measured and tabulate the read.

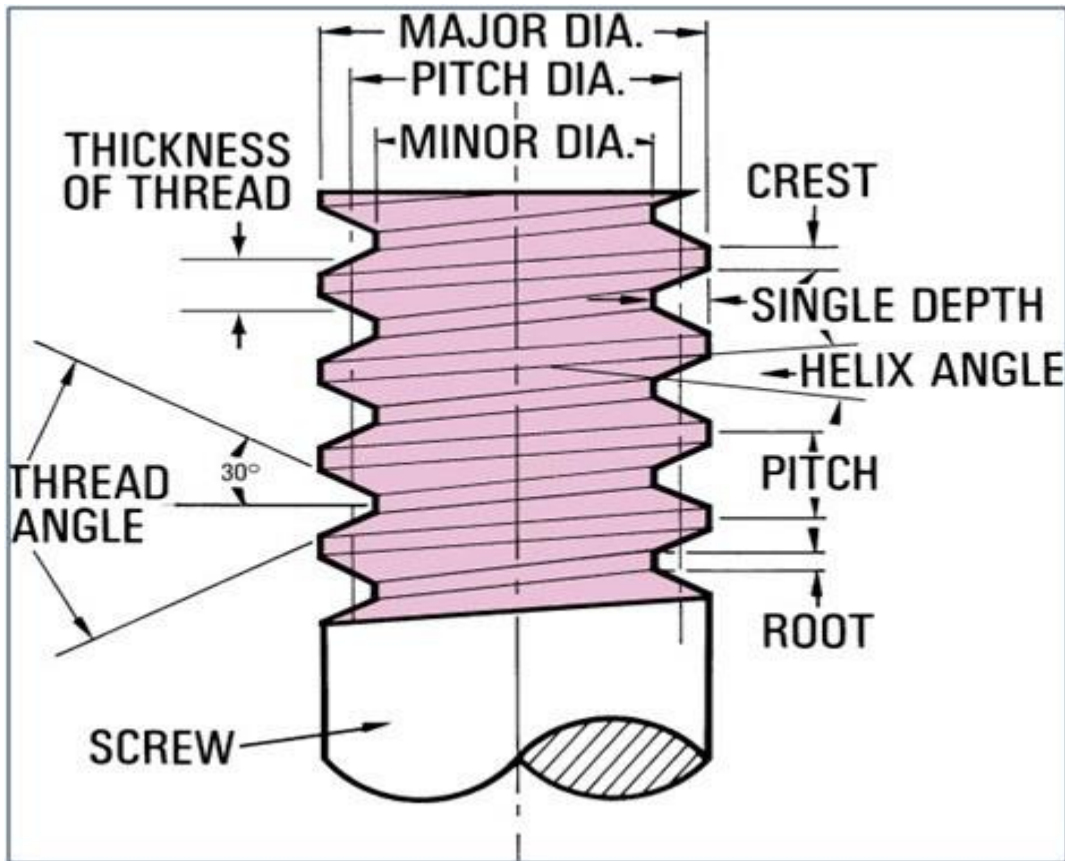

Fig: Nomenclature Of Thread



TABULATION (Taper Angle)

S.No	Initial angle degree	Final angle degree	difference degree	Average degree
1				
2				

TABULATION (Thread Parameters)

Sl.no	Dimension to be measured	Initial point (B) mm	Final point (C) mm	Difference (D) mm
1	PITCH			
2	DEPTH			
3	MAJOR DIAMETER			
4	MINOR DIAMTER			

RESULT

Thus the thread parameters of given screw thread was found using profile projector

- ❖ Major diameter of the screw = ----- ‘mm’
- ❖ Minor diameter of the screw = ----- ‘mm’
- ❖ Pitch of screw = ----- ‘mm’
- ❖ Depth of screw = ----- ‘mm’
- ❖ Angle of thread = ----- ‘degree’

Ex. No: 6b

Date:

MEASUREMENT OF THREAD PARAMETERS USING FLOATING CARRIAGE MICROMETER

AIM

To measure the major diameter, minor diameter & Effective diameter by using floating carriage micrometer.

APPARATUS REQUIRED

- Floating carriage micrometer.
- Specimen
- Prism
- Wire
- Cylinder.

FORMULA

Major Diameter Measurement:

$$OD = D + (R_s - R)$$

Where D = Diameter of setting master.

R_s = Micro meter reading over setting master.

R = Micro meter reading over threaded W/P or gauges.

+ Or – is determined by relative size of master & work piece.

Minor Diameter Measurement:

$$ID = D - (R - R_o)$$

Where D = Diameter of setting master.

C = Core or minor diameter of work piece.

R_p = Reading over master & prism

R = Reading over thread & prism.

Measurement of effective diameter :

$$E = T + P$$

$$T = D + (R_w - R_{ow})$$

ME 8513 METROLOGY AND MEASUREMENTS LABORATORY

Where,

E = Effective or pitch diameter.

T = Measured dimension using cylinder.

R_w = Reading measured over setting master with wire.

R_{ow} = Reading measured over work piece over wire.

$$P = (0.86603 * p) - W$$

W = Mean diameter of cylinder wire used = 1.35 mm

p = Pitch of thread = 2 mm

PROCEDURE

1. The setting master is held b/w center and taken the reading at the diameter say R_s
2. The master cylinder is then replaced by a threaded work piece and R is taken.
3. Take the reading on micrometer and indicator in such a way that radius portion of prism touches master.
4. The cylinder or wire should be chosen so that when placed b/w the threads, they should contact about halfway down the flanks.



TABULATION

Sl.no	Description	Valve(mm)
1	PITCH	
2	MAJOR DIAMETER	
3	MINOR DIAMETER	
4	EFFECTIVE DIAMETER	

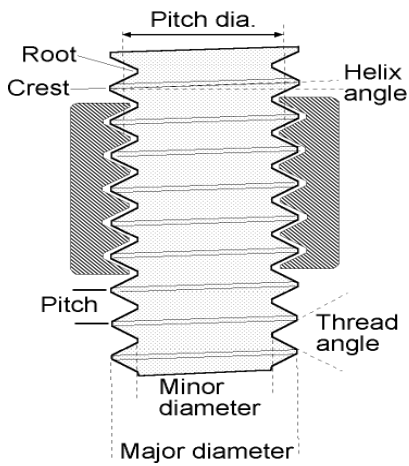
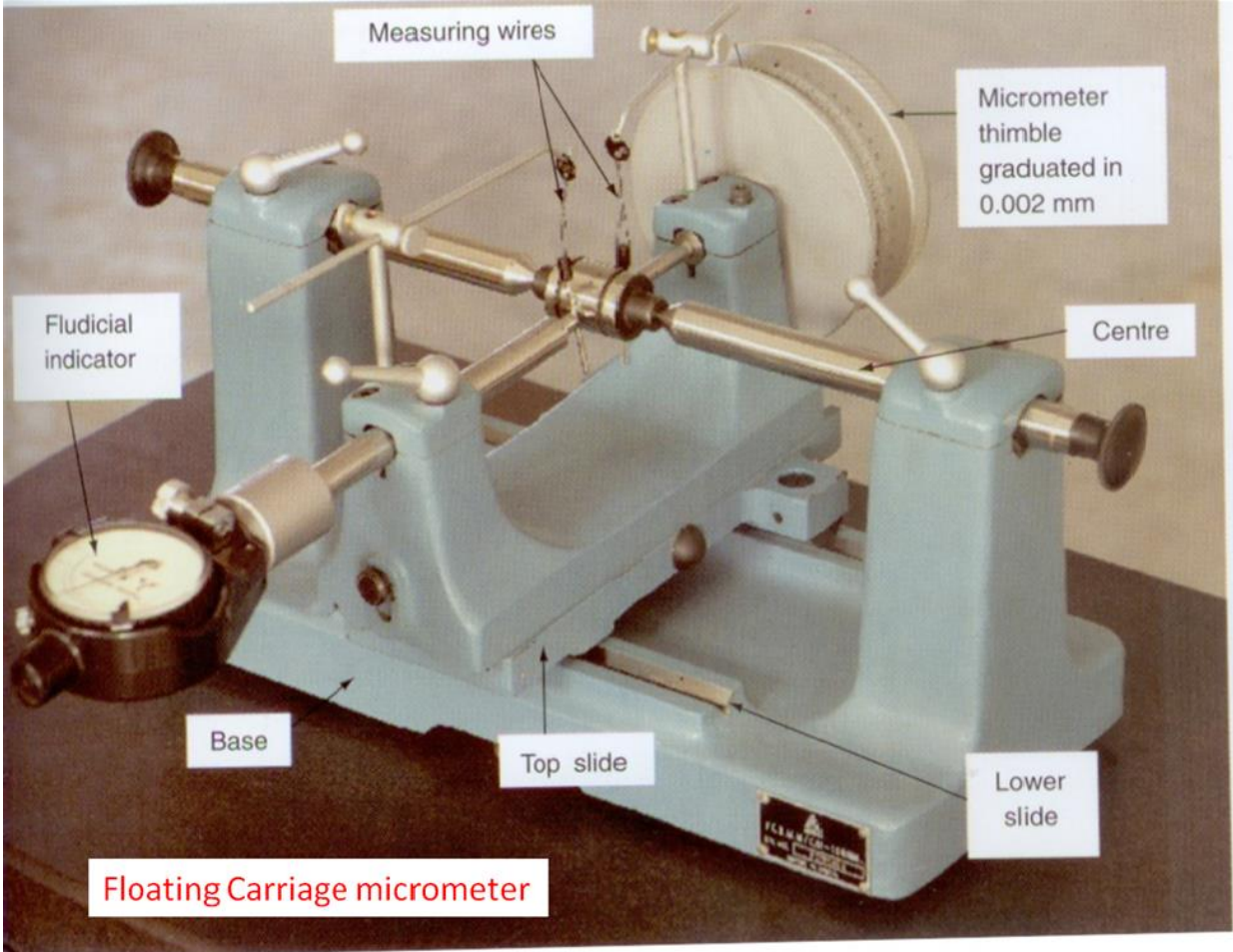

Fig: NOMENCLATURE OF THREAD

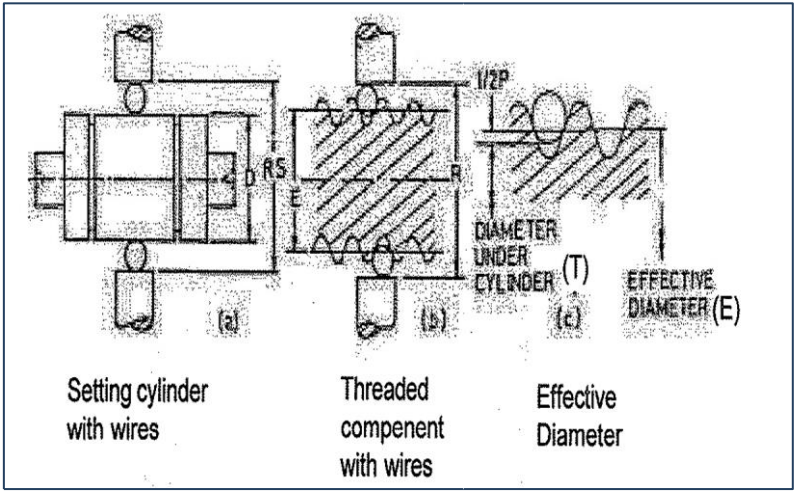

Fig: TWO WIRE METHOD

Observation :

- Diameter of setting cylinder (D) = mm
- Micrometer reading over wire on setting cylinder (Rs) = mm.
- Micrometer reading over wire on threaded component (R) = mm.
- Diameter of wires used (d) = mm
- Pitch of thread (p) = mm.

CALCULATION

RESULT

Thus, the thread parameters are measured using floating carriage micrometer.

Ex. No: 7a

Date:

SETTING UP OF COMPARATORS FOR INSPECTION (PNEUMATIC COMPARATOR)

Aim:

To check the machined component with standard dimensioned component using Pneumatic comparator.

Apparatus Required:

- Pneumatic comparator
- Air compressor
- Ring gauge
- Work piece

Theory:

Comparator means compare the product to its standard and find the deviation from the Standard value. There are different types of comparators to measure various dimensions in different methods like pneumatic, electric, Mechanical and optical.

Procedure:

1. The equipment consists of two setting masters for setting lower and higher value limits
2. One is set to be lower limit let us 01
3. Another is higher limit let us 10.
4. Depend upon the pressure variation this to be held and changed in to scale as in microns
5. The variation is brought you by change value in CAL button in the display
6. Now using above do some specimen on the piece and Check whether they accepted or not.

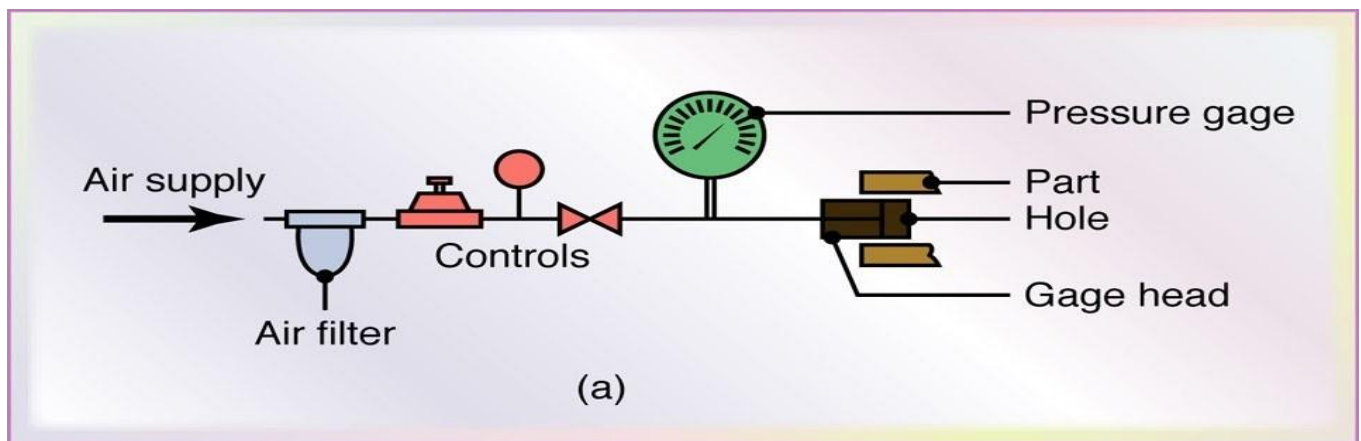

Fig: PNEUMATIC COMPARATOR LAYOUT



Fig: PNEUMATIC COMPARATOR

TABULATION: (Tolerance Limit= +0.012, -0.012. “mm”)

Least count of Pneumatic comparator = 0.001 ‘mm’

Sl.no	Specimen	Actual size Ring gauge (mm)	Pneumatic comparator reading (mm)	Tolerance Limit (mm)	Error	Result
1	I	26.528				
2	II	26.528				
3	III	26.528				
4	IV	26.528				

CALCULATION:

RESULT:

Thus the machined component with standard dimensioned component using Pneumatic comparator.

Ex. No: 7b

Date:

<p style="text-align: center;">SETTING UP OF COMPARATORS FOR INSPECTION (MECHANICAL COMPARATOR)</p>
--

AIM:

To check the height of the machined component with standard dimensioned component using Mechanical comparator.

TOOLS REQUIRED:

- Slip gauge set
- Mechanical comparator
- Surface plate
- Work Piece

PROCEDURE:

1. The slip gauges are built up to the given weight of the component.
2. Dial gauge with stand is placed on the surface plate.
3. The built up gauge is placed under the plunger.
4. The indicator is set to zero.
5. The built up gauge is removed.
6. The given machined component is placed under the plunger.
7. The variation in the height of the component is noted from the reading of the dial.

Dial gauge :

Dial gauges divided in two categories, type1 & type2 for general engineering purpose depending upon the movement of the plunger. These are manufactured in two grades, grade a and grade b, with total plunger movement or lift of 3,5 and 10mm. Type1 dial gauge has the plunger movement parallel to the plane of dial and type 2 has the plunger movement perpendicular to the plane of dial.

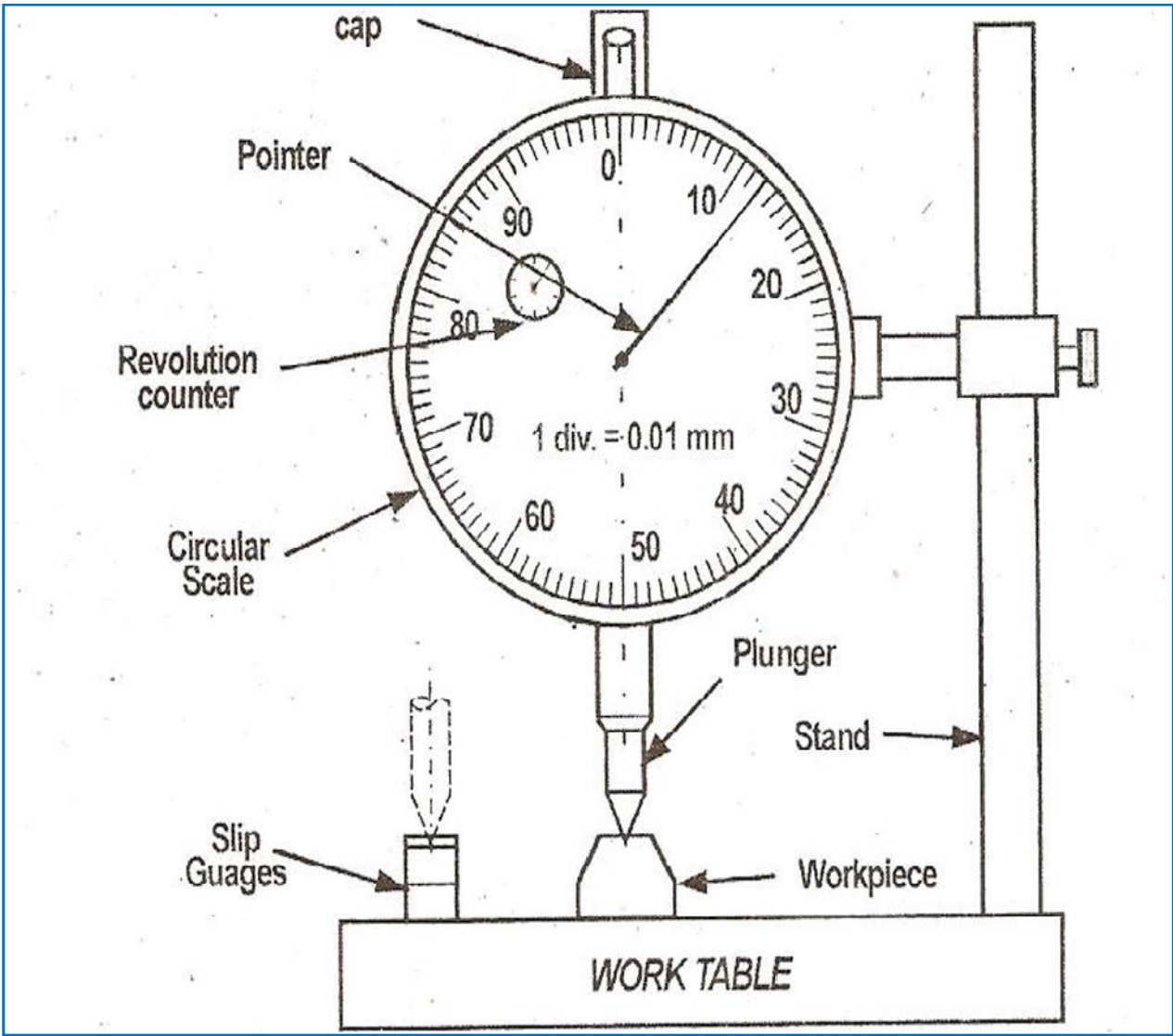

Fig: Mechanical comparator



TABULATION: (Least count of Mechanical comparator= 0.01 mm)

Sl.no	Specimen	Actual size slip gauge (mm)	Mechanical comparator reading (mm)		Actual size Work piece (mm)	Error	Result
			SCR	LCR			
1	I						
2	II						
3	III						
4	IV						

RESULT:

Thus the height of the machined component with standard dimensioned component using Mechanical comparator.

Ex. No: 8

Date:

TEMPERATURE MEASUREMENT

AIM:

To measure temperature using thermometer and RTD, thermocouple.

APPARATUS REQUIRED:

- Temperature indicator
- Electric kettle
- water
- Thermocouple
- Thermometer
- RTD

FORMULA USED:

$$\text{Error} = T1 - T4$$

$$\% \text{ Error} = \frac{\text{Error}}{T4} \times 100$$

Where ,

- T1 is the actual temperature.
- T4 is the thermocouple indicated temperature.

PROCEDURE:

1. Clean the instrument and its accessories by fine cotton cloth.
2. Check connection made and switch on the instrument by rocker switch.
3. The display glows to indicate is on.
4. Allow the instruments in on position for 10 minutes for initial warm up.
5. Fill around 3/4th full of water to the kettle and place the thermometer and thermocouple Inside the kettle.
6. Note down the initial water temperature from the thermometer. Adjust the initial set potentiometer in the front panel till the display reads initial water temperature
7. Switch on the kettle and wait till the water boils note down the thermometer reading and set Potentiometer till the display reads boiling water temperature.
8. Remove the thermometer and temperature sensor from the Kettle and change the water and replace
9. The thermometer reading and set final set potentiometer till the display reads boiling water Temperature
10. Switch on the kettle and note down the reading for every 10 ° interval and tabulate the readings

TABULATION:

S.NO	Actual temperature °C	Indicated temperature °C			Error (T1-T4)	% Error
	Thermometer (T1)	Thermocouple (T2)	RTD (T3)	Average temp (T4)		
1						
2						
3						
5						
6						
7						
8						
9						
10						

CALCULATION:

Graph:

❖ Actual Temperature Vs Indicator Temperature
(Thermometer) (RTD, Thermocouple)

RESULT:

Thus the measure temperature using thermometer and RTD, thermocouple.

Ex. No: 9

Date:

FORCE MEASUREMENT USING LOAD CELL

AIM:

To measure the force using load cell apparatus.

APPARATUS REQUIRED

- > Force measurement trainer Kit (LOAD CELL)
- > Weight
- > Force indicator

FORMULA USED:

Error = Calculated force – Indicated force

$$\% \text{ Error} = \frac{\text{force}}{\text{maximum force}} \times 100 \text{ (Maximum force} = 9.81)$$

$$F = m \times g \text{ (N)}$$

Where,

- m = Mass (kg)
- g = Gravity (m/s²)

PROCEDURE:

1. Clean the instrument and its accessories by fine cotton cloth.
2. Check connection made and switch on the instrument by rocker switch at the front panel.
3. The display glows to indicate is ON.
4. Allow the instrument is on ON position for 10 mins for initial warm-up
5. adjust the potentiometer in the front panel till the display reads Zero
6. Apply the ON load sensor using the weight blocks and note down the readings.
7. The Maximum load carrying capacity of a Sensor is 1 kg



TABULATION :(FORCE)

S.NO	ACTUAL LOAD (kg)	CALCULATED FORCE $F = m \times g$ (N)	INDICATED FORCE (N)	ERROR	% ERROR
1.					
2.					
3.					
4.					
5.					
6.					
7.					
8.					
9.					
10.					

CALCULATION

Graph:

- ❖ Observed Force Vs Calculated Force
- ❖ Observed Force Vs Error

Result:

Thus the force measurement by using load cell.

Ex. No: 10

Date:

MEASUREMENT OF TORQUE USING TORQUE MEASURING SETUP

AIM:

To measure the torque using torque sensor.

APPARATUS REQUIRED:

- Torque sensor
- Stand
- Lever
- weights

PROCEDURE:

1. Check connection made and switch ON the instrument by rocker switch at the front Panel.
2. Allow the instrument in ON position for 10 minutes for initial warm up
3. Adjust the potentiometer in the front panel till the display reads 00.0
4. Apply load to the fulcrum arm by adding dead weights in steps of 100g
5. The instruments reads the load on the sensor and displays through LED
6. Readings can be tabulated

FORMULA:

$$\% \text{ Error} = \frac{\text{error}}{\text{maximum error}} \times 100$$

$$\text{Calculated Torque} = \text{Load} \times \text{Distance}$$

TABULATION: (TORQUE) DISTANCE = -----

S.no	Actual load (kg)	Observed Torque (N- m)	Calculated Torque(N-m)	Error	% Error
1					
2					
3					
4					
5					

ME 8513 METROLOGY AND MEASUREMENTS LABORATORY

TABULATION: (TORQUE) DISTANCE = -----

S.no	Actual load (kg)	Observed Torque (N- m)	Calculated Torque (N-m)	Error	% Error
1					
2					
3					
4					
5					

CALCULATION:

Graph:

- ❖ Observed Torque Vs Calculated Torque
- ❖ Observed Torque Vs Error

Result:

Thus the measurement of torque by using torque sensor.

Ex.No: 11

Date:

BORE DIAMETER MEASUREMENT USING TELESCOPIC GAUGE

AIM

To measure the bore diameter using given telescopic gauge.

APPARATUS REQUIRED

- Telescopic gauge
- Work piece
- Vernier caliper

PROCEDURE

1. Clean the given work piece to be measure
2. Select the telescopic gauge and insert into the cylinder bore.
3. Selected the telescopic gauge from the telescopic gauge set.
4. Unlock the telescopic gauge and inserted into the cylinder bore.
5. Measure the distance of telescopic gauge by using vernier caliper.
6. Tabulate the given readings.

TABULATION Bore Diameter Measurement Using Telescopic Gauge

S.No	Telescopic Gauge range (mm)	Vernier Scale Reading			Bore Diameter (mm)
		MSR	VSC	VSR	

RESULT

Thus the given bore diameter is to be measure by using of telescopic gauge.

Ex.No: 12

Date:

BORE GAUGE

AIM

To measure the cylinder bore using bore gauge.

APPARATUS REQUIRED

1. Cylinder block
2. Bore gauge
3. Vernier caliper

PROCEDURE

1. Measure the bore using vernier caliper to get the gross reading of the bore.
2. Select and install the suitable anvil and washers
3. Make a zero adjustment of the bore gauge using inside measuring jaw of the vernier caliper.
4. After the zero adjustment is done insert the bore gauge into the bore and observe the measurement and record the data.

TABULATION (Bore Gauge)

S. No	Bore Gauge		Dial Gauge			Cylinder Size
	Anvil	Washer's	SCR	VSR	TR= SCR+VSR	

RESULT

Thus the bore measurement by using of bore gauge.

Ex.No: 13

Date:

SURFACE FINISH MEASURING EQUIPMENT

AIM

To measure the surface roughness of the given specimen using roughness testing device.

APPARATUS REQUIRED

- Surface roughness tester
- Work piece

TECHNICAL PARAMETERS

Measurement parameters (R_a , R_z)

Traversed length l = 6 mm

Cut off length = 0.25 + 0.80 mm

Measuring range = 2.5 mm

R_a = 0.05 – 6.5 N/m

R_z = 0.1 -50 N/m

PROCEDURE

1. Clean the given work piece to be measure.
2. Switch on the device and the device is leading to work with screen displaying the measuring parameters and cut off length of the previous test.
3. Before starting the pickup choose the desired parameter R_a (or) R_z and proper cutoff length 2.5, 0.8, 0.25
4. After switch on the devices lighting press the select button and choose R_a (or) R_z lighting press select button and choose l_1 , l_2 , l_3 (0.25, 0.8, 2.5)
5. After the parameter and cut-off length are taken measurement may start.
6. The measurement end's and the screen display the measured value.



TABULATION (Surface Finish Measuring Equipment)

S.No	Parameter	Cut off length	Roughness Value (N/m)

RESULT

Thus the surface roughness of the given specimen is using roughness tester device.